



**||| HENNIG®**

**PROTECT** YOUR SUCCESS

# CABLE CARRIERS

**DRAG CHAINS | ENERGY CHAINS | CABLE CONDUITS | CABLE TRACKS**

Safe processes are profitable processes. We make our customers successful by protecting people and machines from the manufacturing environment and waste.



# AT HENNIG, YOUR **SUCCESS** ALWAYS COMES FIRST.

Hennig Worldwide has been a global leader since 1950, specializing in chip and coolant management, machine protection, and facility safety. We work with a wide variety of manufacturers and other facilities worldwide, helping them create and maintain safe and efficient workplaces. Our commitment to excellence extends beyond our services—we actively contribute to local communities, create regional jobs, and support the global needs of machine tool customers.

## TABLE OF CONTENTS

4-15	KOL Plastic Systems
16-29	PKK Plastic Systems
30-44	SLE Steel Systems
45	Construction & Agriculture Equipment Systems
46-47	Elevating Work Platform Systems
48-55	Design Guidelines, Arrangements, and Wiring
56	Request for Quote
58-59	Facilities & Contacts





# PROTECT YOUR SUCCESS

Safeguard cables, hoses, and electrical lines on machinery and equipment using our versatile cable carriers. Our cable carriers are ideal for a wide range of applications, including robotics, handling, textile industries, water treatment plants, machine tools, and more. They effectively minimize cable wear, reduce stress, prevent entanglement, and enhance operator safety.

Plastic cable carriers are often the preferred choice for most applications. They offer significant advantages such as chemical resistance, a lightweight design, and cost-effectiveness. In cases of heavy payloads or other extreme conditions, steel chains are used. For exceptionally demanding cycles, our hardened (carburized) steel chains ensure exceptional longevity.

Choose from our extensive selection of cable carriers to find the perfect fit for your application. We provide a comprehensive range of options, ensuring that you get the right setup tailored to your specific needs.



# KOL OVERVIEW

## FEATURES

- Integrated Mounting Holes: No need for mounting brackets as the chains come equipped with integrated mounting holes
- Robust and Cost-Effective Design: Offers sturdy yet inexpensive solutions ideal for light-weight applications
- High-Rigid Torsion Behavior: Accommodates high-rigid torsion behavior for comfortable handling
- Pinch Stay Separation: Unique separation design with minimal dimensions
- Smooth Motion: Enjoy smooth motion with no break-in time required
- Wide Temperature Range: Long-term temperature limits are between -20°C and 100°C (-4°F and 212°F)
- Special Variants Available: Silent running, EX-protection, anti-static, and self-extinguishing



## APPLICATIONS

- Robotics
- Paper production
- Handling
- Textile industries
- Transportation
- Wastewater treatment plants

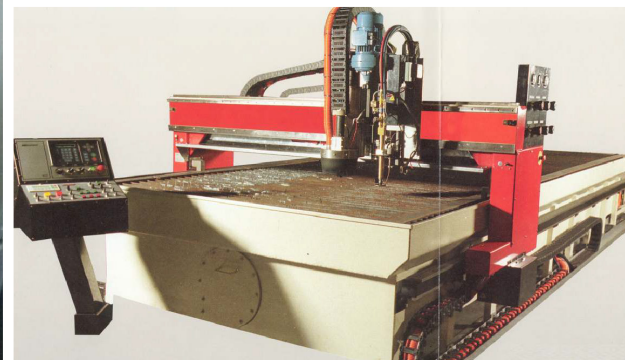
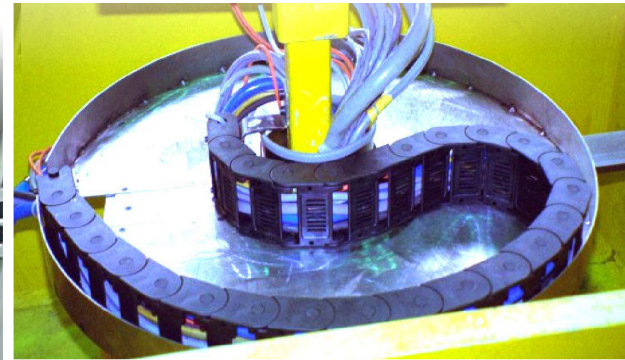
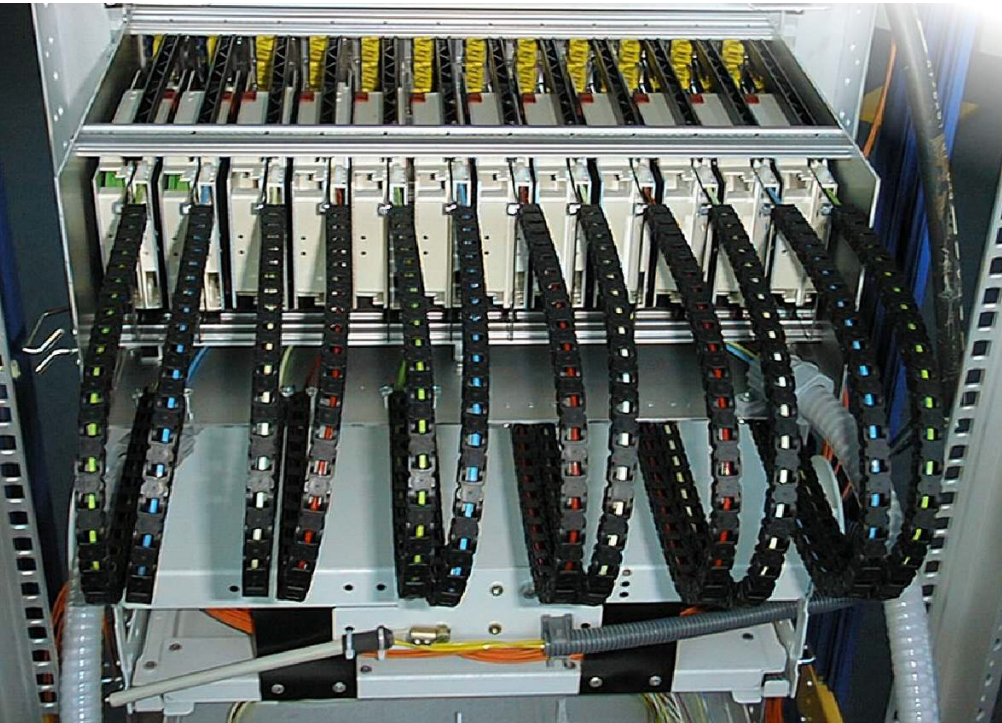



# KOL OVERVIEW

## LOAD DIAGRAM

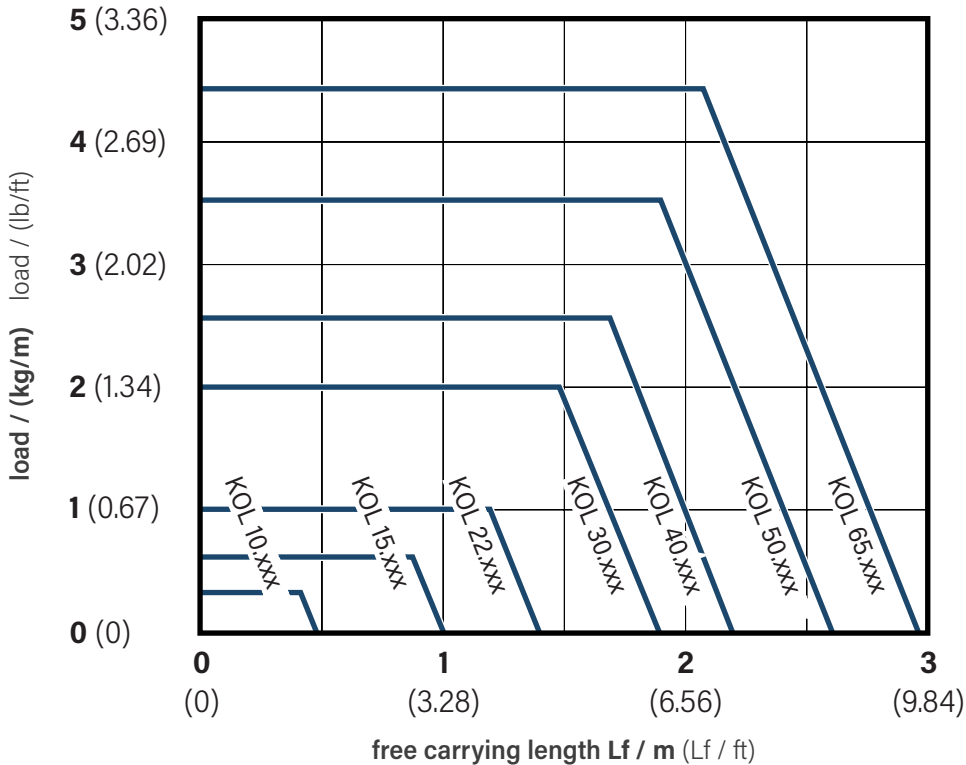

## KOL ORDER EXAMPLE

**Kolibri 10.012.4/50 x 1005**

(type/radius x length)

See pages 9-13 for KOL types

## DIMENSIONS

**bending radii:** 15 - 400 mm (0.59" - 15.75")

**inner height:** 7 - 50 mm (0.28" - 1.97")

**inner width:** 7 - 195 mm (0.28" - 7.68")

**weight:** 0.06 - 2.7 kg/m (0.04 - 1.81 lb/ft)

## TEMPERATURE

Long term temperature limits are between -20°C and 100°C (-4°F and 212°F).

## SPECIAL VARIANTS

- ELTOLA:** silent running
- ATEX:** EX-protection
- ESD:** antistatic
- V-0:** self extinguishing

## TRAVEL DISTANCE

The maximum travel distance is given by the arrangement and the load (weight of the lines). At normal arrangements the maximum travel distance is double the free carrying length. Support rollers or similar equipment may exceed this value. In gliding arrangements travel distances up to 100 m are possible (according to the application).

## TRAVEL SPEED

There are no limits for the travel speed in general, but with gliding arrangements application specific influences have to be taken into account.

## ACCELERATION

There are no limits for the accelerations, in general. Limits may occur through the tensile stresses at high line weights.

# KOL TYPES

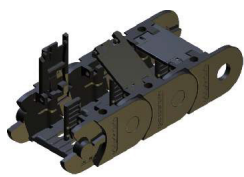
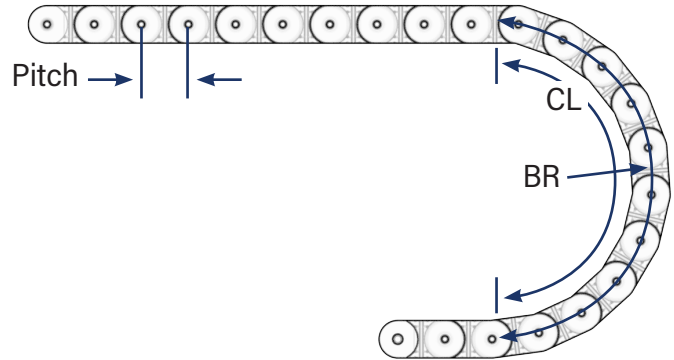
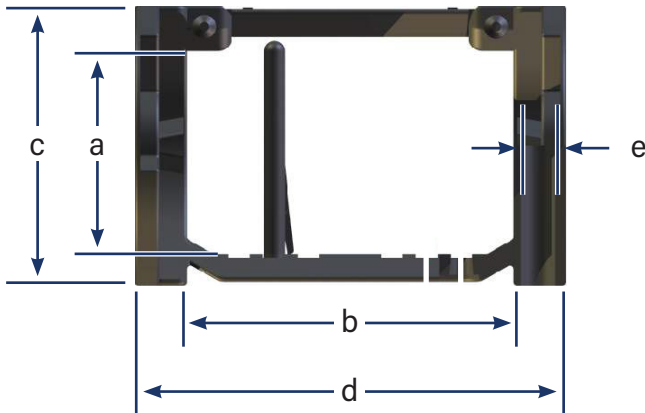

**KOL 00.000.0**

- Standard type
- Flap open bars in inner radius
- Separable with pinch stay
- Integrated connector



**KOL 00.000.4**

- Film stay in inner radius
- Not separable
- Integrated connector

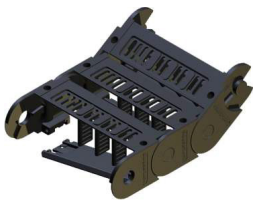

**KOL 00.000.1**

- Openable in outer radius flap
- Open bars in outer radius
- Separable with pinch stay
- Integrated connector



**KOL 00.000.5**

- Closed type
- Flap open covers in outer
- Radius separable with pinch
- Stay integrated connector



**KOL 00.000.2**

- Rigid version
- Flap open bars in inner radius
- Separable with PZ
- Integrated connector



**KOL 00.000.6**

- Equal .2
- Flap open bars in
- Outer radius

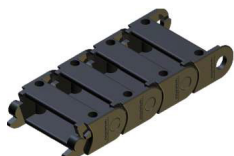

**KOL 00.000.3**

- One part chain links
- Not openable not separable
- Integrated connector

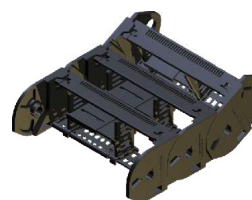

**KOL 00.000.7**

- Telescopic type
- PKK stays in inner radius
- Separable via PZ
- Separate connectors



# KOL DIMENSIONS

All dimensions shown in inches and (mm)

KOL Type	Pitch	a	b	c	d	e	BR	H	CL	Weight (KG/M)
<b>10.012.4</b>	0.59 (15)	0.27 (7)	0.27 (7)	0.39 (10)	0.47 (12)	0.12 (3)	0.59 (15)	1.57 (40)	3.04 (77.10)	0.05
	0.59 (15)	0.27 (7)	0.27 (7)	0.39 (10)	0.47 (12)	0.12 (3)	1.18 (30.0)	2.76 (70)	4.89 (124.20)	0.05
	0.59 (15)	0.27 (7)	0.27 (7)	0.39 (10)	0.47 (12)	0.12 (3)	1.97 (50.0)	4.33 (110)	7.36 (187.00)	0.05
<b>13.023.4</b>	0.79 (20)	0.35 (9)	0.55 (14)	0.51 (13)	0.90 (23)	0.12 (3)	0.69 (17.5)	1.89 (48)	3.74 (94.95)	0.12
	0.79 (20)	0.35 (9)	0.55 (14)	0.51 (13)	0.90 (23)	0.12 (3)	1.38 (35.0)	3.27 (83)	5.90 (149.90)	0.12
<b>15.015.3 .4</b>	0.79 (20)	0.39 (10)	0.39 (10)	0.59 (15)	0.59 (15)	0.16 (4)	0.69 (17.5)	1.97 (50)	3.74 (94.95)	0.15
	0.79 (20)	0.39 (10)	0.39 (10)	0.59 (15)	0.59 (15)	0.16 (4)	0.79 (20.0)	2.17 (55)	4.05 (102.80)	0.15
	0.79 (20)	0.39 (10)	0.43 (11)	0.59 (15)	0.59 (15)	0.16 (4)	1.18 (30.0)	2.95 (75)	5.28 (134.20)	0.15
<b>15.036.5</b>	0.71 (18)	0.39 (10)	0.98 (25)	0.59 (15)	1.42 (36)	0.16 (4)	1.18 (30.0)	2.95 (75)	5.13 (130.20)	0.30
	0.71 (18)	0.39 (10)	0.98 (25)	0.59 (15)	1.42 (36)	0.16 (4)	1.97 (50.0)	4.53 (115)	7.60 (193.00)	0.30
<b>15.037.3</b>	0.79 (20)	0.79 (20)	0.79 (20)	0.79 (20)	1.46 (37)	0.16 (4)	0.94 (24.0)	2.68 (68)	4.54 (115.36)	0.30
	0.79 (20)	0.79 (20)	0.79 (20)	0.79 (20)	1.46 (37)	0.16 (4)	1.18 (30.0)	3.15 (80)	5.28 (134.20)	0.30
<b>15.051.0</b>	0.79 (20)	0.39 (10)	1.54 (39)	0.59 (15)	2.01 (51)	0.16 (4)	0.79 (20.0)	2.17 (55)	4.05 (102.80)	0.35
	0.79 (20)	0.39 (10)	1.54 (39)	0.59 (15)	2.01 (51)	0.16 (4)	1.18 (30.0)	2.95 (75)	5.28 (134.20)	0.35
<b>22.025.4</b>	1.18 (30)	1.18 (30)	1.18 (30)	1.18 (30)	1.18 (30)	0.16 (4)	1.38 (35.0)	3.94 (100)	6.69 (169.90)	0.20
	1.18 (30)	1.18 (30)	1.18 (30)	1.18 (30)	1.18 (30)	0.16 (4)	2.76 (70.0)	6.69 (170)	11.02 (279.80)	0.20
	1.18 (30)	1.18 (30)	1.18 (30)	1.18 (30)	1.18 (30)	0.16 (4)	3.94 (100.0)	9.06 (230)	14.72 (374.00)	0.20
<b>22.038.0 .1</b>	1.02 (26)	0.67 (17)	1.06 (27)	0.87 (22)	1.50 (38)	0.16 (4)	1.38 (35.0)	3.62 (92)	6.38 (161.90)	0.34
	1.02 (26)	0.67 (17)	1.06 (27)	0.87 (22)	1.50 (38)	0.16 (4)	1.97 (50.0)	4.80 (122)	8.23 (209.00)	0.34
	1.02 (26)	0.67 (17)	1.06 (27)	0.87 (22)	1.50 (38)	0.16 (4)	2.36 (60.0)	5.59 (142)	9.46 (240.40)	0.34
	1.02 (26)	0.67 (17)	1.06 (27)	0.87 (22)	1.50 (38)	0.16 (4)	2.76 (70.0)	6.38 (162)	10.70 (271.80)	0.34
	1.02 (26)	0.67 (17)	1.06 (27)	0.87 (22)	1.50 (38)	0.16 (4)	3.94 (100.0)	8.74 (222)	14.41 (366.00)	0.34
<b>22.048.0</b>	1.18 (30)	0.67 (17)	1.42 (36)	0.87 (22)	1.89 (48)	0.16 (4)	1.38 (35.0)	3.62 (92)	6.69 (169.90)	0.37
	1.18 (30)	0.67 (17)	1.42 (36)	0.87 (22)	1.89 (48)	0.16 (4)	2.76 (70.0)	6.38 (162)	11.02 (279.80)	0.37
<b>22.060.5</b>	1.02 (26)	0.63 (16)	1.89 (48)	0.87 (22)	2.36 (60)	0.16 (4)	1.97 (50.0)	4.80 (122)	8.23 (209.00)	0.54
	1.02 (26)	0.63 (16)	1.89 (48)	0.87 (22)	2.36 (60)	0.16 (4)	2.76 (70.0)	6.38 (162)	10.70 (271.80)	0.54
	1.02 (26)	0.63 (16)	1.89 (48)	0.87 (22)	2.36 (60)	0.16 (4)	3.94 (100.0)	8.74 (222)	14.41 (366.00)	0.54

# KOL DIMENSIONS

All dimensions shown in inches and (mm)

KOL Type	Pitch	a	b	c	d	e	BR	H	CL	Weight (KG/M)
<b>30.030.3</b>	1.57 (40)	0.94 (24)	0.71 (18)	1.18 (30)	1.18 (30)	0.16 (4)	1.57 (40.0)	4.33 (110)	8.09 (205.60)	0.50
	1.57 (40)	0.94 (24)	0.71 (18)	1.18 (30)	1.18 (30)	0.16 (4)	3.94 (100.0)	9.05 (230)	15.51 (394.00)	0.50
	1.57 (40)	0.94 (24)	0.71 (18)	1.18 (30)	1.18 (30)	0.16 (4)	7.87 (200.0)	16.93 (430)	27.87 (708.00)	0.50
<b>30.060.3</b>	1.57 (40)	0.94 (24)	1.89 (48)	1.18 (30)	2.36 (60)	0.16 (4)	1.57 (40.0)	4.33 (110)	8.09 (205.60)	0.60
	1.57 (40)	0.94 (24)	1.89 (48)	1.18 (30)	2.36 (60)	0.16 (4)	3.94 (100.0)	9.05 (230)	15.51 (394.00)	0.60
	1.57 (40)	0.94 (24)	1.89 (48)	1.18 (30)	2.36 (60)	0.16 (4)	5.90 (150.0)	12.99 (330)	21.69 (551.00)	0.60
	1.57 (40)	0.94 (24)	1.89 (48)	1.18 (30)	2.36 (60)	0.16 (4)	7.87 (200.0)	16.93 (430)	27.87 (708.00)	0.60
<b>30.050.0.1.5</b>	1.38 (35)	1.38 (35)	1.38 (35)	1.38 (35)	1.38 (35)	0.20 (5)	1.57 (40.0)	4.53 (115)	7.70 (195.60)	0.54
	1.38 (35)	1.38 (35)	1.38 (35)	1.38 (35)	1.38 (35)	0.20 (5)	2.36 (60.0)	6.10 (155)	10.17 (258.40)	0.54
	1.38 (35)	1.38 (35)	1.38 (35)	1.38 (35)	1.38 (35)	0.20 (5)	2.95 (75.0)	7.28 (185)	12.03 (305.50)	0.54
	1.38 (35)	1.38 (35)	1.38 (35)	1.38 (35)	1.38 (35)	0.20 (5)	3.94 (100.0)	9.25 (235)	15.12 (384.00)	0.54
	1.38 (35)	1.38 (35)	1.38 (35)	1.38 (35)	1.38 (35)	0.20 (5)	5.90 (150.0)	13.19 (335)	21.30 (541.00)	0.54
	1.38 (35)	1.38 (35)	1.38 (35)	1.38 (35)	1.38 (35)	0.20 (5)	7.87 (200.0)	17.13 (435)	27.48 (698.00)	0.54
<b>30.060.0.1</b>	1.38 (35)	1.38 (35)	1.38 (35)	1.38 (35)	2.36 (60)	0.20 (5)	1.57 (40.0)	4.53 (115)	7.70 (195.60)	0.61
	1.38 (35)	1.38 (35)	1.38 (35)	1.38 (35)	2.36 (60)	0.20 (5)	1.97 (50.0)	5.31 (135)	8.94 (227.00)	0.61
	1.38 (35)	1.38 (35)	1.38 (35)	1.38 (35)	2.36 (60)	0.20 (5)	2.95 (75.0)	7.28 (185)	12.03 (305.50)	0.61
	1.38 (35)	1.38 (35)	1.38 (35)	1.38 (35)	2.36 (60)	0.20 (5)	3.94 (100.0)	9.25 (235)	15.12 (384.00)	0.61
	1.38 (35)	1.38 (35)	1.38 (35)	1.38 (35)	2.36 (60)	0.20 (5)	5.90 (150.0)	13.19 (335)	21.30 (541.00)	0.61
	1.38 (35)	1.38 (35)	1.38 (35)	1.38 (35)	2.36 (60)	0.20 (5)	7.87 (200.0)	17.13 (435)	27.48 (698.00)	0.61
<b>30.080.0.1.2.4.5</b>	1.38 (35)	1.38 (35)	1.38 (35)	1.38 (35)	3.15 (80)	0.20 (5)	1.57 (40.0)	4.53 (115)	7.70 (195.60)	0.65
	1.38 (35)	1.38 (35)	1.38 (35)	1.38 (35)	3.15 (80)	0.20 (5)	2.36 (60.0)	6.10 (155)	10.17 (258.40)	0.65
	1.38 (35)	1.38 (35)	1.38 (35)	1.38 (35)	3.15 (80)	0.20 (5)	2.95 (75.0)	7.28 (185)	12.03 (305.50)	0.65
	1.38 (35)	1.38 (35)	1.38 (35)	1.38 (35)	3.15 (80)	0.20 (5)	3.94 (100.0)	9.25 (235)	15.12 (384.00)	0.65
	1.38 (35)	1.38 (35)	1.38 (35)	1.38 (35)	3.15 (80)	0.20 (5)	5.90 (150.0)	13.19 (335)	21.30 (541.00)	0.65
	1.38 (35)	1.38 (35)	1.38 (35)	1.38 (35)	3.15 (80)	0.20 (5)	7.87 (200.0)	17.13 (435)	27.48 (698.00)	0.65



# KOL DIMENSIONS

All dimensions shown in inches and (mm)

KOL Type	Pitch	a	b	c	d	e	BR	H	CL	Weight (KG/M)
<b>30.095.0 .1</b>	1.38 (35)	0.91 (23)	3.11 (79)	1.18 (30)	3.74 (95)	0.20 (5)	1.57 (40.0)	4.33 (110)	7.70 (195.60)	0.75
	1.38 (35)	0.91 (23)	3.11 (79)	1.18 (30)	3.74 (95)	0.20 (5)	2.95 (75.0)	7.09 (180)	12.03 (305.50)	0.75
	1.38 (35)	0.91 (23)	3.11 (79)	1.18 (30)	3.74 (95)	0.20 (5)	3.94 (100.0)	9.06 (230)	15.12 (384.00)	0.75
	1.38 (35)	0.91 (23)	3.11 (79)	1.18 (30)	3.74 (95)	0.20 (5)	4.92 (125.0)	11.02 (280)	18.21 (462.50)	0.75
	1.38 (35)	0.91 (23)	3.11 (79)	1.18 (30)	3.74 (95)	0.20 (5)	5.91 (150.0)	12.99 (330)	21.30 (541.00)	0.75
	1.38 (35)	0.91 (23)	3.11 (79)	1.18 (30)	3.74 (95)	0.20 (5)	7.87 (200.0)	16.93 (430)	27.48 (698.00)	0.75
<b>30.125.0 .1</b>	1.38 (35)	0.91 (23)	4.29 (109)	1.18 (30)	4.92 (125)	0.20 (5)	1.57 (40.0)	4.33 (110)	7.70 (195.60)	0.87
	1.38 (35)	0.91 (23)	4.29 (109)	1.18 (30)	4.92 (125)	0.20 (5)	2.95 (75.0)	7.09 (180)	12.03 (305.50)	0.87
	1.38 (35)	0.91 (23)	4.29 (109)	1.18 (30)	4.92 (125)	0.20 (5)	3.94 (100.0)	9.06 (230)	15.12 (384.00)	0.87
	1.38 (35)	0.91 (23)	4.29 (109)	1.18 (30)	4.92 (125)	0.20 (5)	5.91 (150.0)	12.99 (330)	21.30 (541.00)	0.87
	1.38 (35)	0.91 (23)	4.29 (109)	1.18 (30)	4.92 (125)	0.20 (5)	7.87 (200.0)	16.93 (430)	27.48 (698.00)	0.87
<b>40.062.2 .5</b>	1.77 (45)	1.14 (29)	1.89 (48)	1.57 (40)	2.44 (62)	0.20 (5)	2.36 (60.0)	6.30 (160)	10.96 (278.40)	0.91
	1.77 (45)	1.14 (29)	1.89 (48)	1.57 (40)	2.44 (62)	0.20 (5)	2.95 (75.0)	7.48 (190)	12.81 (325.50)	0.91
	1.77 (45)	1.14 (29)	1.89 (48)	1.57 (40)	2.44 (62)	0.20 (5)	3.94 (100.0)	9.45 (240)	15.91 (404.00)	0.91
	1.77 (45)	1.14 (29)	1.89 (48)	1.57 (40)	2.44 (62)	0.20 (5)	5.91 (150.0)	13.39 (340)	22.09 (561.00)	0.91
	1.77 (45)	1.14 (29)	1.89 (48)	1.57 (40)	2.44 (62)	0.20 (5)	7.87 (200.0)	17.32 (440)	28.27 (718.00)	0.91
<b>40.075.2 .6</b>	1.77 (45)	1.14 (29)	2.36 (60)	1.57 (40)	2.95 (75)	0.20 (5)	2.36 (60.0)	6.30 (160)	10.96 (278.40)	1.05
	1.77 (45)	1.14 (29)	2.36 (60)	1.57 (40)	2.95 (75)	0.20 (5)	2.95 (75.0)	7.48 (190)	12.81 (325.50)	1.05
	1.77 (45)	1.14 (29)	2.36 (60)	1.57 (40)	2.95 (75)	0.20 (5)	3.94 (100.0)	9.45 (240)	15.91 (404.00)	1.05
	1.77 (45)	1.14 (29)	2.36 (60)	1.57 (40)	2.95 (75)	0.20 (5)	5.91 (150.0)	13.39 (340)	22.09 (561.00)	1.05
	1.77 (45)	1.14 (29)	2.36 (60)	1.57 (40)	2.95 (75)	0.20 (5)	7.87 (200.0)	17.32 (440)	28.27 (718.00)	1.05
<b>40.112.7</b>	1.46 (37)	1.22 (31)	1.97 (50)	3.94 (100)	-	0.20 (5)	2.17 (55.0)	8.27 (210)	9.71 (246.70)	1.05
<b>50.065.0 .5</b>	2.17 (55)	1.57 (40)	1.89 (48)	1.97 (50)	2.56 (65)	0.27 (6)	2.95 (75.0)	7.87 (200)	13.60 (345.50)	1.30
	2.17 (55)	1.57 (40)	1.89 (48)	1.97 (50)	2.56 (65)	0.27 (6)	3.94 (100.0)	9.84 (250)	16.69 (424.00)	1.30
	2.17 (55)	1.57 (40)	1.89 (48)	1.97 (50)	2.56 (65)	0.27 (6)	4.92 (125.0)	11.81 (300)	19.78 (502.50)	1.30
	2.17 (55)	1.57 (40)	1.89 (48)	1.97 (50)	2.56 (65)	0.27 (6)	5.91 (150.0)	13.78 (350)	22.87 (581.00)	1.30
	2.17 (55)	1.57 (40)	1.89 (48)	1.97 (50)	2.56 (65)	0.27 (6)	7.87 (200.0)	17.72 (450)	29.06 (738.00)	1.30
	2.17 (55)	1.57 (40)	1.89 (48)	1.97 (50)	2.56 (65)	0.27 (6)	9.84 (250.0)	21.65 (550)	35.24 (895.00)	1.30

# KOL DIMENSIONS

All dimensions shown in inches and (mm)

KOL Type	Pitch	a	b	c	d	e	BR	H	CL	Weight (KG/M)
<b>50.065.0 .5</b>	2.17 (55)	1.57 (40)	1.89 (48)	1.97 (50)	2.56 (65)	0.24 (6)	2.95 (75.0)	7.87 (200)	13.58 (345.50)	1.30
	2.17 (55)	1.57 (40)	1.89 (48)	1.97 (50)	2.56 (65)	0.24 (6)	3.94 (100.0)	9.84 (250)	16.69 (424.00)	1.30
	2.17 (55)	1.57 (40)	1.89 (48)	1.97 (50)	2.56 (65)	0.24 (6)	4.92 (125.0)	11.81 (300)	19.78 (502.50)	1.30
	2.17 (55)	1.57 (40)	1.89 (48)	1.97 (50)	2.56 (65)	0.24 (6)	5.91 (150.0)	13.78 (350)	22.87 (581.00)	1.30
	2.17 (55)	1.57 (40)	1.89 (48)	1.97 (50)	2.56 (65)	0.24 (6)	7.87 (200.0)	17.72 (450)	29.06 (738.00)	1.30
	2.17 (55)	1.57 (40)	1.89 (48)	1.97 (50)	2.56 (65)	0.24 (6)	9.84 (250.0)	21.65 (550)	35.24 (895.00)	1.30
<b>50.095.0 .1 .2 .5</b>	2.17 (55)	1.57 (40)	3.07 (78)	1.97 (50)	3.74 (95)	0.24 (6)	2.95 (75.0)	7.87 (200)	13.58 (345.50)	1.35
	2.17 (55)	1.57 (40)	3.07 (78)	1.97 (50)	3.74 (95)	0.24 (6)	3.94 (100.0)	9.84 (250)	16.69 (424.00)	1.35
	2.17 (55)	1.57 (40)	3.07 (78)	1.97 (50)	3.74 (95)	0.24 (6)	4.92 (125.0)	11.81 (300)	19.78 (502.50)	1.35
	2.17 (55)	1.57 (40)	3.07 (78)	1.97 (50)	3.74 (95)	0.24 (6)	5.91 (150.0)	13.78 (350)	22.87 (581.00)	1.35
	2.17 (55)	1.57 (40)	3.07 (78)	1.97 (50)	3.74 (95)	0.24 (6)	6.89 (175.0)	15.75 (400)	25.96 (659.50)	1.35
	2.17 (55)	1.57 (40)	3.07 (78)	1.97 (50)	3.74 (95)	0.24 (6)	7.87 (200.0)	17.72 (450)	29.06 (738.00)	1.35
	2.17 (55)	1.57 (40)	3.07 (78)	1.97 (50)	3.74 (95)	0.24 (6)	9.84 (250.0)	21.65 (550)	35.24 (895.00)	1.35
<b>50.125.0 .1</b>	2.17 (55)	1.57 (40)	4.25 (108)	1.97 (50)	4.92 (125)	0.24 (6)	2.95 (75.0)	7.87 (200)	13.58 (345.50)	1.52
	2.17 (55)	1.57 (40)	4.25 (108)	1.97 (50)	4.92 (125)	0.24 (6)	3.94 (100.0)	9.84 (250)	16.69 (424.00)	1.52
	2.17 (55)	1.57 (40)	4.25 (108)	1.97 (50)	4.92 (125)	0.24 (6)	4.92 (125.0)	11.81 (300)	19.78 (502.50)	1.52
	2.17 (55)	1.57 (40)	4.25 (108)	1.97 (50)	4.92 (125)	0.24 (6)	5.91 (150.0)	13.78 (350)	22.87 (581.00)	1.52
	2.17 (55)	1.57 (40)	4.25 (108)	1.97 (50)	4.92 (125)	0.24 (6)	7.87 (200.0)	17.72 (450)	29.06 (738.00)	1.52
	2.17 (55)	1.57 (40)	4.25 (108)	1.97 (50)	4.92 (125)	0.24 (6)	9.84 (250.0)	21.65 (550)	35.24 (895.00)	1.52



# KOL DIMENSIONS

All dimensions shown in inches and (mm)

KOL Type	Pitch	a	b	c	d	e	BR	H	CL	Weight (KG/M)
<b>50.150.0 .1 .5</b>	2.17 (55)	1.57 (40)	5.24 (133)	1.97 (50)	5.91 (150)	0.24 (6)	2.95 (75.0)	7.87 (200)	13.58 (345.50)	1.90
	2.17 (55)	1.57 (40)	5.24 (133)	1.97 (50)	5.91 (150)	0.24 (6)	3.94 (100.0)	9.84 (250)	16.69 (424.00)	1.90
	2.17 (55)	1.57 (40)	5.24 (133)	1.97 (50)	5.91 (150)	0.24 (6)	5.91 (150.0)	13.78 (350)	22.87 (581.00)	1.90
	2.17 (55)	1.57 (40)	5.24 (133)	1.97 (50)	5.91 (150)	0.24 (6)	7.87 (200.0)	17.72 (450)	29.06 (738.00)	1.90
	2.17 (55)	1.57 (40)	5.24 (133)	1.97 (50)	5.91 (150)	0.24 (6)	9.84 (250.0)	21.65 (550)	35.24 (895.00)	1.90
<b>65.095.1 .5</b>	2.76 (70)	1.97 (50)	3.03 (77)	2.56 (65)	3.74 (95)	0.24 (6)	4.92 (125.0)	12.40 (315)	20.96 (532.50)	2.20
	2.76 (70)	1.97 (50)	3.03 (77)	2.56 (65)	3.74 (95)	0.24 (6)	5.91 (150.0)	14.37 (365)	24.06 (611.00)	2.20
	2.76 (70)	1.97 (50)	3.03 (77)	2.56 (65)	3.74 (95)	0.24 (6)	7.87 (200.0)	18.31 (465)	30.24 (768.00)	2.20
	2.76 (70)	1.97 (50)	3.03 (77)	2.56 (65)	3.74 (95)	0.24 (6)	11.81 (300.0)	26.18 (665)	42.60 (1082.00)	2.20
<b>65.135.1 .5</b>	2.76 (70)	1.97 (50)	4.61 (117)	2.56 (65)	5.31 (135)	0.24 (6)	4.92 (125.0)	12.40 (315)	20.96 (532.50)	2.60
	2.76 (70)	1.97 (50)	4.61 (117)	2.56 (65)	5.31 (135)	0.24 (6)	5.91 (150.0)	14.37 (365)	24.06 (611.00)	2.60
	2.76 (70)	1.97 (50)	4.61 (117)	2.56 (65)	5.31 (135)	0.24 (6)	7.87 (200.0)	18.31 (465)	30.24 (768.00)	2.60
	2.76 (70)	1.97 (50)	4.61 (117)	2.56 (65)	5.31 (135)	0.24 (6)	11.81 (300.0)	26.18 (665)	42.60 (1082.00)	2.60

# KOL SIZES

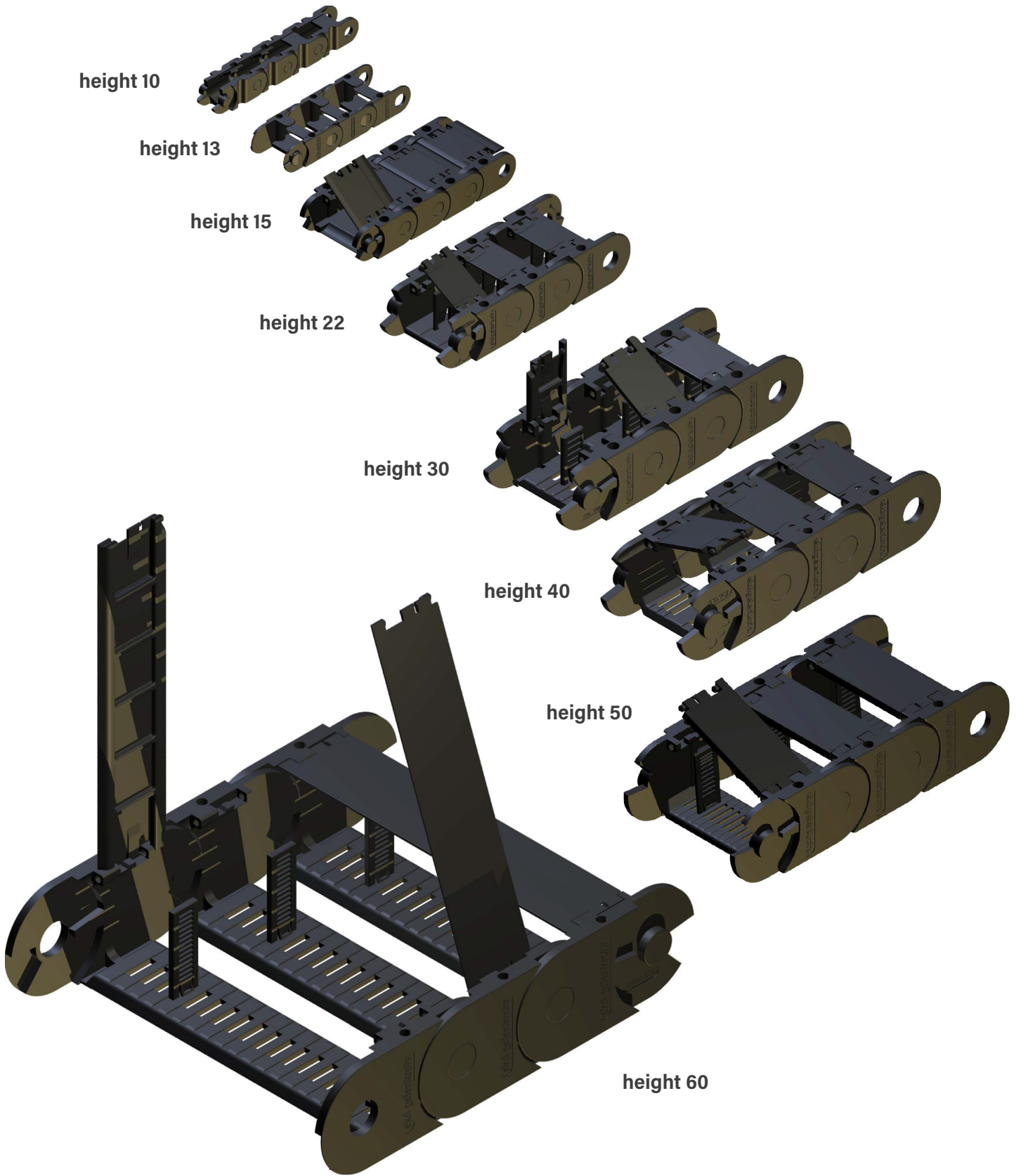

# KOL SPARE PARTS

- 1 link (open type)
- 2 link (closed type)
- 3 flange pivot
- 4 flange drilling
- 5 horn stay connector
- 6 horn stay 65 HS65
- 7 horn stay 85 HS85
- 8 damping element
- 9 PZ (divider)
- 10 PZ (pinch stay)
- 11 flap stay
- 12 flap cover
- 13 notched horizontal divider
- 14 notched horizontal divider flying
- 15 telescopic horizontal divider
- 16 telescopic horizontal divider flying
- 17 ladderstay
- 18 connector 10.012.4 hole
- 19 connector 10.012.4 pivot

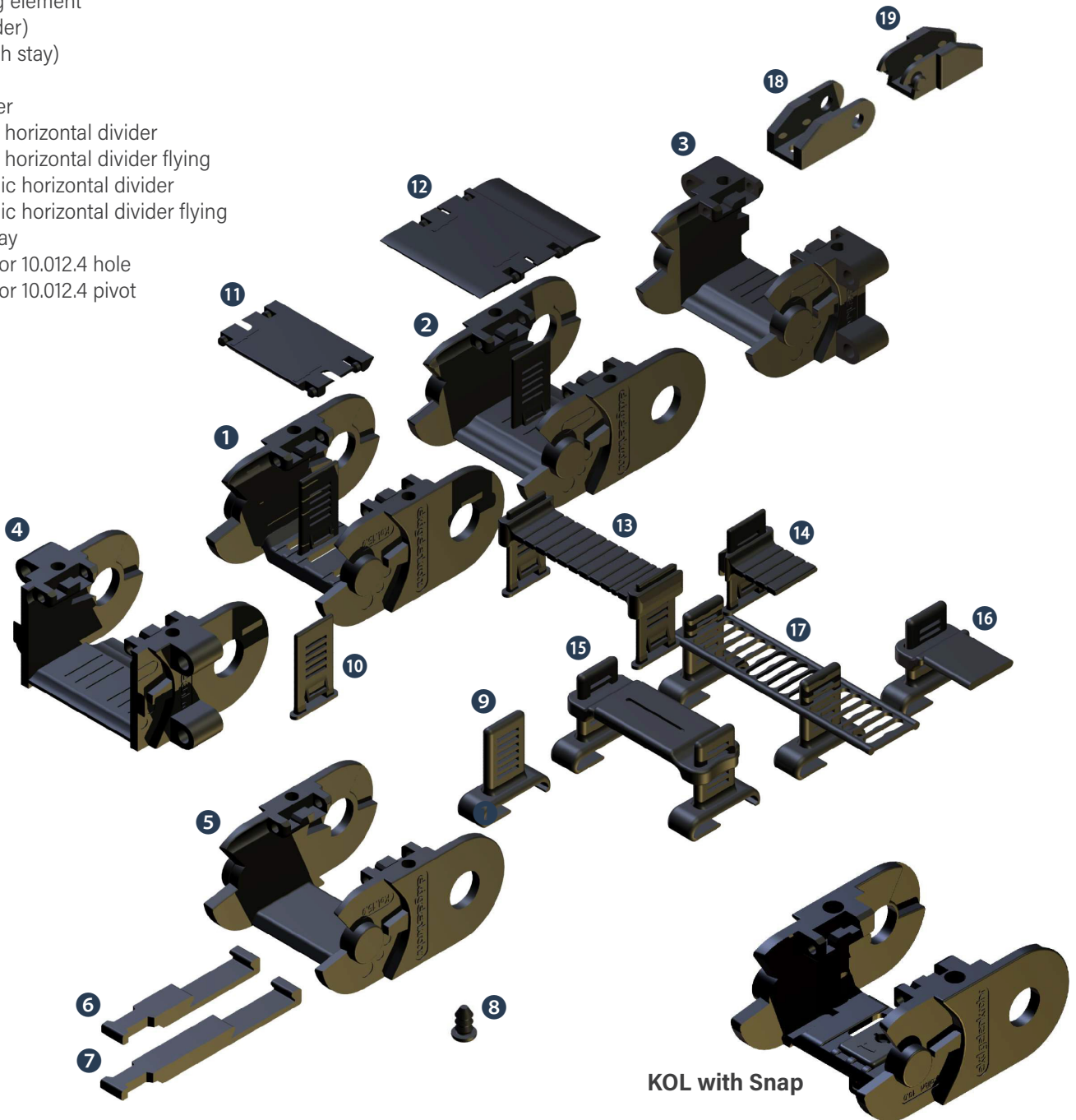

# KOL ASSEMBLY

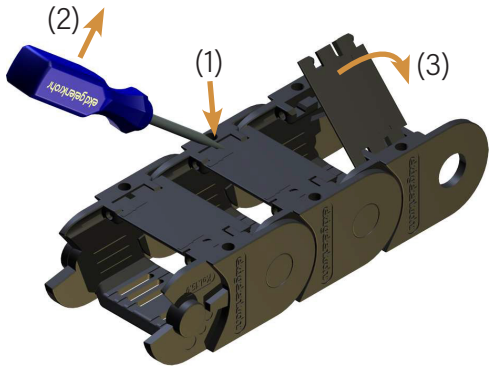

## OPENING AND CLOSING

Push a screwdriver as shown in the slot (1) then with a light lever movement (2) raise the tongue and push the locking pins of the flap stay (or the flap cover) out of the drilling. The flap stay can then be lifted (3). To remove the flap stay the second side has to be unlocked and the stay has to be pushed out against the direction of the cones.

The installation of the flap stays and flap covers are snapped in a slight angle with the pins against the corresponding drillings (4) and with slight pressure against the locking tongue. Lifted flap stays can be re-engaged (5) with slight pressure.

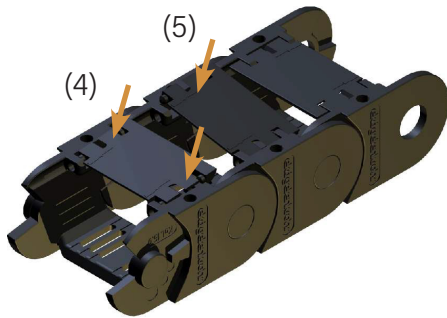

## LENGTHENING AND SHORTENING

To lengthen or shorten the flap stays have to be opened. The walls with pivot pins are to press internally (1) and the walls with the holes are to press toward the outside (2). The chain links can be pushed together (3), or be pulled apart.

## INSTALLATION OF THE FLAP STAYS

The assembly of the flap stays can take place before or after cable lining. Therefore cable carrier does not need to be opened. The flap stays are inserted from the outside chain link floor until snap (1), (2). The dismantling of the stays is done by unlocking the tongue and pushing out (3).

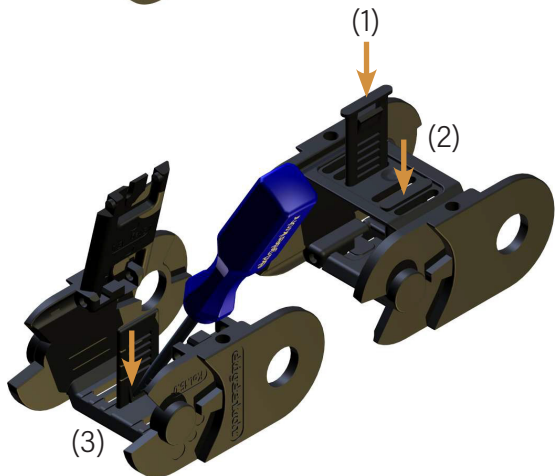
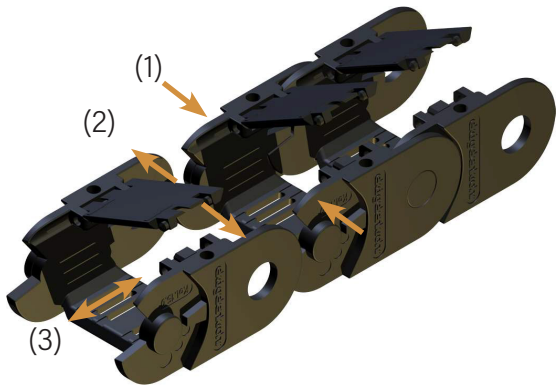



# KOL ASSEMBLY

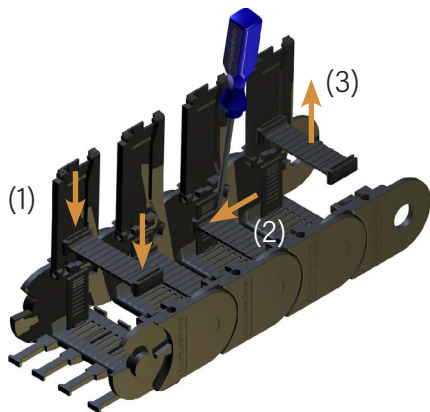

## ASSEMBLY OF HORIZONTAL DIVIDERS

The horizontal dividers (notched, telescopic and ladderstay) are horizontally slid onto the vertical dividers (PZ) (1).

With a screwdriver the locking tongue can be mounted (2) and horizontal dividers disassembled (3).

## MOUNTING THE Cable carrier AND STRAIN RELIEF

Before mounting the cable carrier horn stays may be assembled which can be used to fix the lines via cable ties. For most applications variable strain relief is recommended, to mount the anchor profile with the cable carrier using the integrated connector. (1), (2).

It is also possible to attach the anchor profile as a separate strain relief. The anchor profile is suitable for various strain relief components.

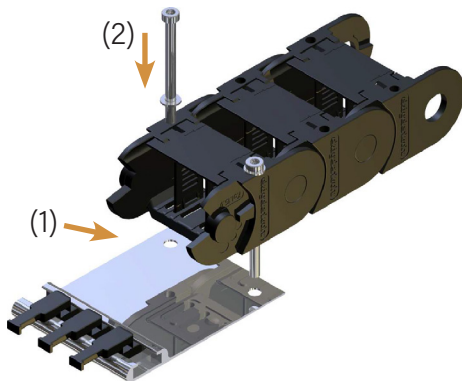

## SNAP ASSEMBLY

The cable carrier may be assembled with only one click using the snap connector. Horn stays will be clipped at the stays as strain relief elements. After that the cable carrier can be clicked in the designated position.

## MAINTENANCE OF THE Cable carrier

KOL cable carriers are maintenance free. Like every mechanical system there will be—depending on the ambient conditions—wear which must be observed. In case of this the cable carrier space has to be exchanged.

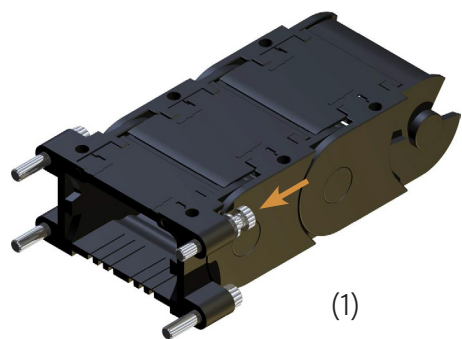
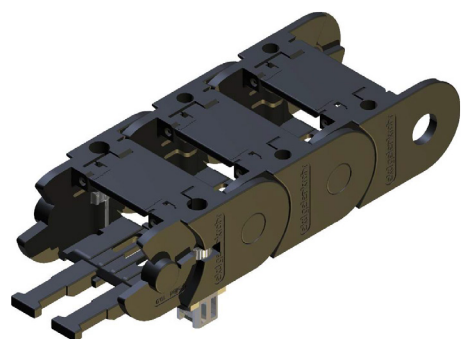

# PKK OVERVIEW

## PKK FEATURES

- **Durable Construction:** Boasting plastic sidebands, the PKK system offers a wide variety of frame stays that offer robustness and longevity
- **Versatile Frame Stay Options:** Choose from plastic bars or lids, round aluminum bars with plastic rollers, or wide aluminum bars or lids for enhanced strength, wear resistance, and added protection
- **Streamlined Installation:** Each link comes with integrated mounting holes, often eliminating the need for additional mounting brackets, saving you time and effort
- **Enhanced Stability:** Our locking link-to-link connection design increases strength and enables unsupported spans, ensuring reliable performance even in demanding applications
- **Easy Assembly/Disassembly:** The fast stay assembly and disassembly design simplifies maintenance and adjustments, minimizing downtime
- **Exceptional Rigidity and Wear Resistance:** Extremely rigid and wear resistant, ensuring reliable cable protection and reducing the risk of damage
- **Quick Length Adjustment:** Enjoy quick and easy length adjustment to accommodate varying cable lengths and configurations, providing flexibility for your setup
- **Smooth Motion:** Smooth motion right from the start, eliminating the need for break-in time
- **Travel Distance:** The maximum distance of travel is determined by the arrangement and additional weight of the lines, but normal arrangement provides a maximum travel of double the free carrying length; travel distances up to 100 meters are possible
- **Travel Speed and Acceleration:** There are no limits to travel speed or accelerations in general, but application-specific influences may limit this such as line weight (support rollers or similar constructive steps can increase this value)
- **Wide Temperature Range:** Long term temperature limits are between -20°C and 100°C (-4°F and 212°F).



## APPLICATIONS

- Robotics
- Handling
- Machine tools
- Textile industries

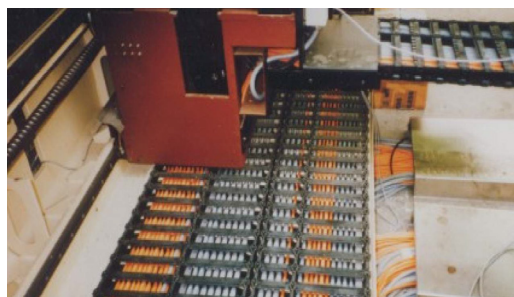

# PKK OVERVIEW

## LOAD DIAGRAM

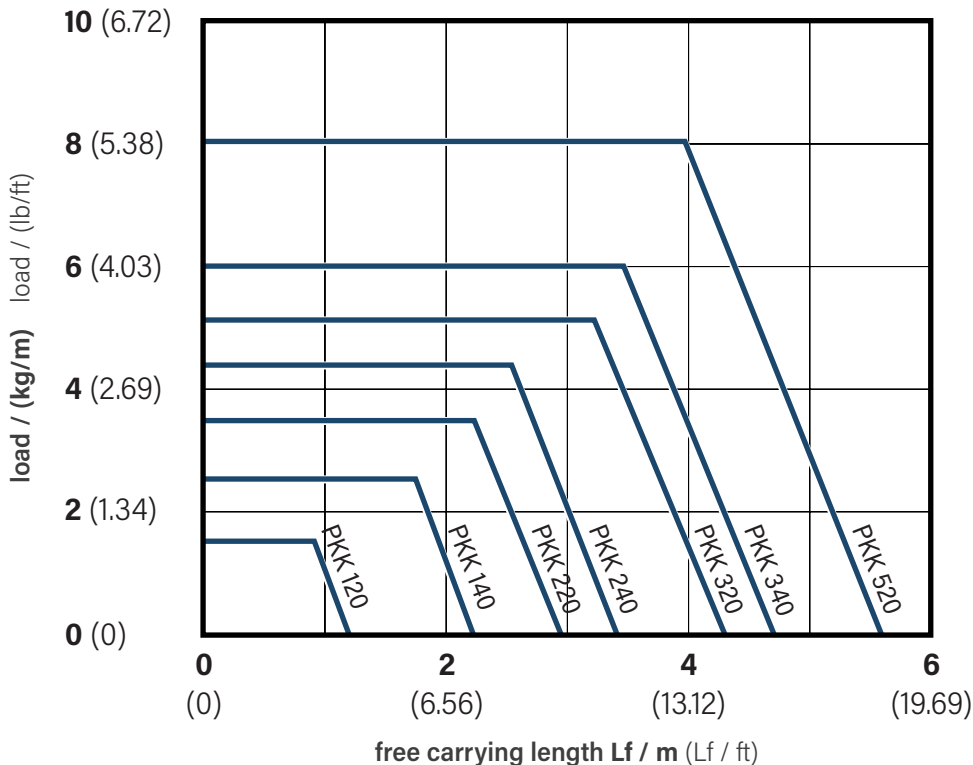

## PKK ORDER EXAMPLE

**PKK 220/100 x 3510/100**  
 (type/radius x length/stay length)  
 See pages 20-23 for PKK types

## DIMENSIONS

**bending radii:** 40 - 500 mm (1.57" - 19.69")  
**inner height:** 16 - 80 mm (0.63" - 3.15")  
**inner width:** 30 - 400 mm (1.18" - 15.75")  
**weight:** 0.6 - 3.4 kg/m (0.40 - 2.28 lb/ft)

## TEMPERATURE

Long term temperature limits are between -20°C and 100°C (-4°F and 212°F).

## SPECIAL VARIANTS

**ELTOLA:** silent running  
**ALLROUND:** all movements  
**ATEX:** EX-protection  
**ESD:** antistatic  
**V-0:** self extinguishing

## TRAVEL DISTANCE

The maximum range of travel is determined by the arrangement and the additional weight (line weight). At normal arrangement the maximum travel is double free carrying length. Support rollers or similar constructive steps can increase this value. Travel distances up to 100 meters are possible.

## TRAVEL SPEED

There are no limits for the travel speed in general, but with gliding arrangements application specific influences have to be taken into account.

## ACCELERATION

There are no limits for the accelerations, in general. Limits may occur through the tensile stresses at high line weights.

# PKK DIMENSIONS

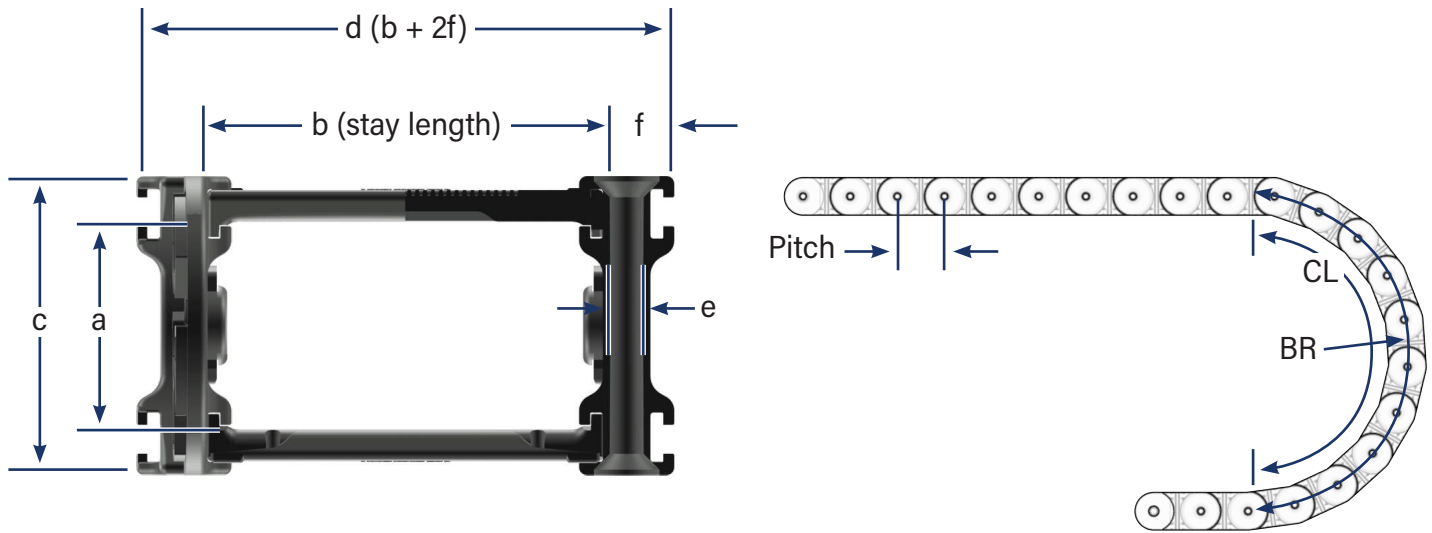

See page 29 for dimension B (stay lengths available)

All dimensions shown in inches and (mm). See page 23 for dimension b (stay lengths available).

PKK Type	Pitch	a	c	f	e	BR	H	CL	Weight (KG/M)
<b>120, 121, 123, 125</b>	1.38 (35)	0.63 (16)	0.98 (25)	0.43 (11)	0.16 (4)	1.57 (40)	4.13 (105)	7.70 (195.6)	0.60
	1.38 (35)	0.63 (16)	0.98 (25)	0.43 (11)	0.16 (4)	1.97 (50)	4.92 (125)	8.94 (227.0)	0.60
	1.38 (35)	0.63 (16)	0.98 (25)	0.43 (11)	0.16 (4)	2.36 (60)	5.71 (145)	10.17 (258.4)	0.60
	1.38 (35)	0.63 (16)	0.98 (25)	0.43 (11)	0.16 (4)	2.95 (75)	6.89 (175)	12.03 (305.5)	0.60
<b>110, 111, 113, 115</b>	1.38 (35)	0.63 (16)	0.98 (25)	0.31 (8)	0.16 (4)	1.57 (40)	4.13 (105)	7.70 (195.6)	0.60
	1.38 (35)	0.63 (16)	0.98 (25)	0.31 (8)	0.16 (4)	1.97 (50)	4.92 (125)	8.94 (227.0)	0.60
	1.38 (35)	0.63 (16)	0.98 (25)	0.31 (8)	0.16 (4)	2.36 (60)	5.71 (145)	10.17 (258.4)	0.60
	1.38 (35)	0.63 (16)	0.98 (25)	0.31 (8)	0.16 (4)	2.95 (75)	6.89 (175)	12.03 (305.5)	0.60
<b>140, 141, 143</b>	2.13 (54)	1.18 (30)	1.57 (40)	0.35 (9)	0.16 (4)	1.97 (50)	5.51 (140)	10.43 (265.0)	1.03
	2.13 (54)	1.18 (30)	1.57 (40)	0.35 (9)	0.16 (4)	2.36 (60)	6.30 (160)	11.67 (296.4)	1.03
	2.13 (54)	1.18 (30)	1.57 (40)	0.35 (9)	0.16 (4)	3.15 (80)	7.87 (200)	14.14 (359.2)	1.03
	2.13 (54)	1.18 (30)	1.57 (40)	0.35 (9)	0.16 (4)	3.94 (100)	9.45 (240)	16.61 (422.0)	1.03
	2.13 (54)	1.18 (30)	1.57 (40)	0.35 (9)	0.16 (4)	5.91 (150)	13.39 (340)	22.80 (579.0)	1.03
	2.13 (54)	1.18 (30)	1.57 (40)	0.35 (9)	0.16 (4)	7.87 (200)	17.32 (440)	28.98 (736.0)	1.03



# PKK DIMENSIONS

All dimensions shown in inches and (mm). See page 23 for dimension b (stay lengths available).

PKK Type	Pitch	a	c	f	e	BR	H	CL	Weight (KG/M)
<b>220, 221, 223, 225, 228</b>	2.56 (65)	1.34 (34)	1.97 (50)	0.59 (15)	0.24 (6)	2.95 (75)	7.87 (200)	14.39 (365.5)	1.5
	2.56 (65)	1.34 (34)	1.97 (50)	0.59 (15)	0.24 (6)	3.94 (100)	9.84 (250)	17.48 (444.0)	1.5
	2.56 (65)	1.34 (34)	1.97 (50)	0.59 (15)	0.24 (6)	5.91 (150)	13.78 (350)	23.66 (601.0)	1.5
	2.56 (65)	1.34 (34)	1.97 (50)	0.59 (15)	0.24 (6)	7.87 (200)	17.72 (450)	29.84 (758.0)	1.5
	2.56 (65)	1.34 (34)	1.97 (50)	0.59 (15)	0.24 (6)	9.84 (250)	21.65 (550)	36.02 (915.0)	1.5
	2.56 (65)	1.34 (34)	1.97 (50)	0.59 (15)	0.24 (6)	11.81 (300)	25.59 (650)	42.20 (1072.0)	1.5
<b>210, 211, 213, 215</b>	2.56 (65)	1.34 (34)	1.97 (50)	0.39 (10)	0.24 (6)	2.56 (65)	7.09 (180)	13.15 (334.1)	1.4
	2.56 (65)	1.34 (34)	1.97 (50)	0.39 (10)	0.24 (6)	2.95 (75)	7.87 (200)	14.39 (365.5)	1.4
	2.56 (65)	1.34 (34)	1.97 (50)	0.39 (10)	0.24 (6)	3.94 (100)	9.84 (250)	17.32 (444.0)	1.4
	2.56 (65)	1.34 (34)	1.97 (50)	0.39 (10)	0.24 (6)	4.92 (125)	11.81 (300)	20.57 (522.5)	1.4
	2.56 (65)	1.34 (34)	1.97 (50)	0.39 (10)	0.24 (6)	5.91 (150)	13.78 (350)	23.66 (601.0)	1.4
	2.56 (65)	1.34 (34)	1.97 (50)	0.39 (10)	0.24 (6)	7.87 (200)	17.72 (450)	29.84 (758.0)	1.4
	2.56 (65)	1.34 (34)	1.97 (50)	0.39 (10)	0.24 (6)	9.84 (250)	21.65 (550)	36.02 (915.0)	1.4
	2.56 (65)	1.34 (34)	1.97 (50)	0.39 (10)	0.24 (6)	11.81 (300)	25.59 (650)	42.20 (1072.0)	1.4
<b>240, 241, 243, 245</b>	2.56 (65)	1.73 (44)	2.36 (60)	0.39 (10)	0.24 (6)	2.95 (75)	8.27 (210)	14.39 (365.5)	1.7
	2.56 (65)	1.73 (44)	2.36 (60)	0.39 (10)	0.24 (6)	3.94 (100)	10.24 (260)	17.32 (444.0)	1.7
	2.56 (65)	1.73 (44)	2.36 (60)	0.39 (10)	0.24 (6)	4.92 (125)	12.20 (310)	20.57 (522.5)	1.7
	2.56 (65)	1.73 (44)	2.36 (60)	0.39 (10)	0.24 (6)	5.91 (150)	14.17 (360)	23.66 (601.0)	1.7
	2.56 (65)	1.73 (44)	2.36 (60)	0.39 (10)	0.24 (6)	7.87 (200)	18.11 (460)	29.84 (758.0)	1.7
	2.56 (65)	1.73 (44)	2.36 (60)	0.39 (10)	0.24 (6)	9.84 (250)	22.05 (560)	36.02 (915.0)	1.7
	2.56 (65)	1.73 (44)	2.36 (60)	0.39 (10)	0.24 (6)	11.81 (300)	25.98 (660)	42.20 (1072.0)	1.7
<b>320, 321, 323, 325, 328</b>	3.54 (90)	2.01 (51)	2.95 (75)	0.71 (18)	0.31 (8)	3.94 (100)	10.83 (275)	19.45 (494.0)	2.5
	3.54 (90)	2.01 (51)	2.95 (75)	0.71 (18)	0.31 (8)	5.91 (150)	14.76 (375)	25.63 (651.0)	2.5
	3.54 (90)	2.01 (51)	2.95 (75)	0.71 (18)	0.31 (8)	7.87 (200)	18.70 (475)	31.81 (808.0)	2.5
	3.54 (90)	2.01 (51)	2.95 (75)	0.71 (18)	0.31 (8)	9.84 (250)	22.64 (575)	37.99 (965.0)	2.5
	3.54 (90)	2.01 (51)	2.95 (75)	0.71 (18)	0.31 (8)	11.81 (300)	26.57 (675)	44.17 (1122.0)	2.5
	3.54 (90)	2.01 (51)	2.95 (75)	0.71 (18)	0.31 (8)	15.75 (400)	34.45 (875)	56.54 (1436.0)	2.5

# PKK DIMENSIONS

All dimensions shown in inches and (mm). See page 23 for dimension b (stay lengths available).

PKK Type	Pitch	a	c	f	e	BR	h	CL	Weight (KG/M)
<b>310, 311, 313, 315</b>	3.54 (90)	2.01 (51)	2.95 (75)	0.47 (12)	0.31 (8)	3.94 (100)	10.83 (275)	19.45 (494.0)	2.5
	3.54 (90)	2.01 (51)	2.95 (75)	0.47 (12)	0.31 (8)	5.12 (130)	13.19 (335)	23.16 (588.2)	2.5
	3.54 (90)	2.01 (51)	2.95 (75)	0.47 (12)	0.31 (8)	5.91 (150)	14.76 (375)	25.63 (651.0)	2.5
	3.54 (90)	2.01 (51)	2.95 (75)	0.47 (12)	0.31 (8)	7.87 (200)	18.70 (475)	31.81 (808.0)	2.5
	3.54 (90)	2.01 (51)	2.95 (75)	0.47 (12)	0.31 (8)	9.84 (250)	22.64 (575)	37.99 (965.0)	2.5
	3.54 (90)	2.01 (51)	2.95 (75)	0.47 (12)	0.31 (8)	11.81 (300)	26.57 (675)	44.17 (1122.0)	2.5
	3.54 (90)	2.01 (51)	2.95 (75)	0.47 (12)	0.31 (8)	15.75 (400)	34.45 (875)	56.54 (1436.0)	2.5
<b>340, 341, 343, 345</b>	3.54 (90)	2.40 (61)	3.35 (85)	0.59 (15)	0.31 (8)	3.94 (100)	11.22 (285)	19.45 (494.0)	2.7
	3.54 (90)	2.40 (61)	3.35 (85)	0.59 (15)	0.31 (8)	5.91 (150)	15.16 (385)	25.63 (651.0)	2.7
	3.54 (90)	2.40 (61)	3.35 (85)	0.59 (15)	0.31 (8)	7.87 (200)	19.09 (485)	31.81 (808.0)	2.7
	3.54 (90)	2.40 (61)	3.35 (85)	0.59 (15)	0.31 (8)	9.84 (250)	23.03 (585)	37.99 (965.0)	2.7
	3.54 (90)	2.40 (61)	3.35 (85)	0.59 (15)	0.31 (8)	11.81 (300)	26.97 (685)	44.17 (1122.0)	2.7
	3.54 (90)	2.40 (61)	3.35 (85)	0.59 (15)	0.31 (8)	15.75 (400)	34.84 (885)	56.54 (1436.0)	2.7
<b>520, 521, 523, 525, 528</b>	4.53 (115)	3.15 (80)	4.09 (104)	0.55 (14)	0.31 (8)	5.91 (150)	15.91 (404)	27.60 (701.0)	3.4
	4.53 (115)	3.15 (80)	4.09 (104)	0.55 (14)	0.31 (8)	7.87 (200)	19.84 (504)	33.78 (858.0)	3.4
	4.53 (115)	3.15 (80)	4.09 (104)	0.55 (14)	0.31 (8)	9.84 (250)	23.78 (604)	39.96 (1015.0)	3.4
	4.53 (115)	3.15 (80)	4.09 (104)	0.55 (14)	0.31 (8)	11.81 (300)	27.72 (704)	46.14 (1172.0)	3.4
	4.53 (115)	3.15 (80)	4.09 (104)	0.55 (14)	0.31 (8)	15.75 (400)	35.59 (904)	58.50 (1486.0)	3.4
	4.53 (115)	3.15 (80)	4.09 (104)	0.55 (14)	0.31 (8)	19.69 (500)	15.75 (1104)	70.87 (1800.0)	3.4
<b>510, 511, 513, 515</b>	4.53 (115)	3.15 (80)	4.09 (104)	0.55 (14)	0.31 (8)	5.91 (150)	15.91 (404)	27.60 (701.0)	3.2
	4.53 (115)	3.15 (80)	4.09 (104)	0.55 (14)	0.31 (8)	7.87 (200)	19.84 (504)	33.78 (858.0)	3.2
	4.53 (115)	3.15 (80)	4.09 (104)	0.55 (14)	0.31 (8)	9.84 (250)	23.78 (604)	39.96 (1015.0)	3.2
	4.53 (115)	3.15 (80)	4.09 (104)	0.55 (14)	0.31 (8)	11.81 (300)	27.72 (704)	46.14 (1172.0)	3.2
	4.53 (115)	3.15 (80)	4.09 (104)	0.55 (14)	0.31 (8)	15.75 (400)	35.59 (904)	58.50 (1486.0)	3.2
	4.53 (115)	3.15 (80)	4.09 (104)	0.55 (14)	0.31 (8)	19.69 (500)	15.75 (1104)	70.87 (1800.0)	3.2

# PKK DIMENSIONS

All dimensions shown in inches and (mm)

PKK Type	b (stay lengths available for each PKK type)
<b>110, 111, 113*, 120, 121, 123*</b>	1.18 (30), 1.97 (50), 2.36 (60), 2.76 (70), 3.15 (80), 3.54 (90), 3.94 (100), 4.33 (110), 4.72 (120)
<b>115, 125</b>	1.97 (50), 3.94 (100)
<b>140, 141, 143*</b>	1.18 (30), 1.97 (50), 2.36 (60), 2.76 (70), 3.15 (80), 3.54 (90), 3.94 (100), 4.33 (110), 4.72 (120)
<b>210, 211, 213*, 220, 221, 223*, 228+</b>	1.97 (50), 2.36 (60), 2.76 (70), 3.15 (80), 3.54 (90), 3.94 (100), 4.33 (110), 4.72 (120), 5.12 (130), 5.91 (150),
	6.69 (170), 7.87 (200), 8.66 (220)
<b>215, 2255+</b>	1.97 (50), 3.94 (100), 5.91 (150), 7.87 (200)
<b>240, 241, 243*</b>	1.97 (50), 2.36 (60), 2.76 (70), 3.15 (80), 3.54 (90), 3.94 (100), 4.33 (110), 4.72 (120), 5.12 (130), 5.91 (150),
	6.69 (170), 7.87 (200), 8.66 (220)
<b>2455</b>	1.97 (50), 3.94 (100), 5.91 (150), 7.87 (200)
<b>320, 310, 311, 313*, 321, 323*, 328+</b>	1.97 (50), 2.36 (60), 2.76 (70), 3.15 (80), 3.54 (90), 3.94 (100), 4.72 (120), 5.12 (130), 5.91 (150), 6.69 (170),
	7.09 (180), 7.87 (200), 9.06 (230), 9.84 (250), 10.63 (270), 11.81 (300), 12.99 (330), 15.75 (400)
<b>315, 3255+</b>	3.94 (100), 5.91 (150), 7.87 (200), 11.81 (300)
<b>340, 341, 343*</b>	1.97 (50), 2.36 (60), 2.76 (70), 3.15 (80), 3.54 (90), 3.94 (100), 4.72 (120), 5.12 (130), 5.91 (150), 6.69 (170),
	7.09 (180), 7.87 (200), 9.06 (230), 9.84 (250), 10.63 (270), 11.81 (300), 12.99 (330), 15.75 (400)
<b>3455</b>	3.94 (100), 5.91 (150), 7.87 (200), 11.81 (300)
<b>520, 510, 511, 513*, 521, 523*, 528+</b>	1.97 (50), 2.36 (60), 2.76 (70), 3.15 (80), 3.54 (90), 3.94 (100), 4.72 (120), 5.12 (130), 5.91 (150), 6.69 (170),
	7.09 (180), 7.87 (200), 9.06 (230), 9.84 (250), 10.63 (270), 11.81 (300), 12.99 (330), 15.75 (400)
<b>515, 525</b>	5.91 (150), 7.87 (200)

\* Additional stays available  
 + Sliders available



\* Additional stays



+ Sliders

# PKK TYPES

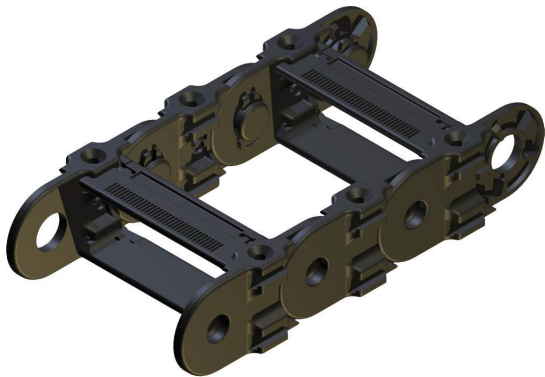

## PKK 120, 220, 320, 520

The standard version has a stay in every second link. With additional link bands and stays the chains can be extended as multiband chains. The integrated connector makes each link in the chain to a mounting link.

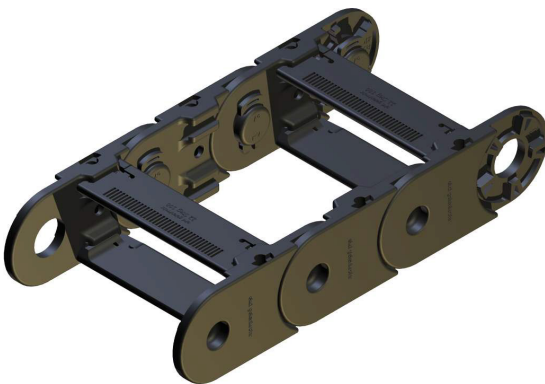

## PKK 110, 140, 210, 240, 310, 340, 510

The smooth designed PKK corresponds to the standard version, but has no exterior T-slot. These types provide a very good visual effect and a smaller width through the flat outside surfaces (also see PKK 215, PKK 245). The PKK 240 and 340 offer larger cross sections due to the increased link height.

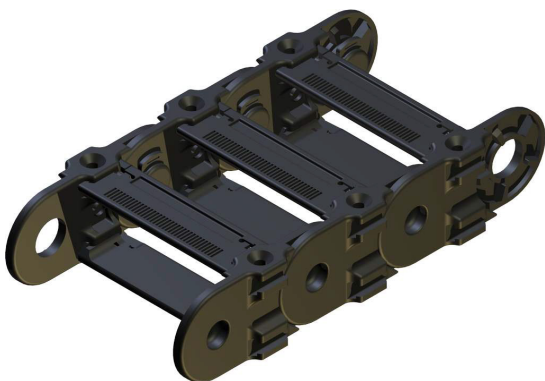

## PKK 121, 221, 321, 521

The types PKK -21 are manufactured with a stay in each link. The additional stays increase the lateral stability and optimize guiding of particularly smaller cable diameter.

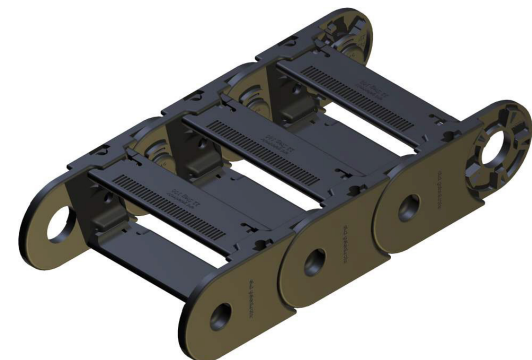

## PKK 111, 141, 211, 241, 311, 341, 511

These are the smooth designs with a stay in each link to increase lateral stability and optimize guiding of particularly small cables. PKK 241 and PKK 341 have a higher capacity due to their increased link height.



# PKK TYPES

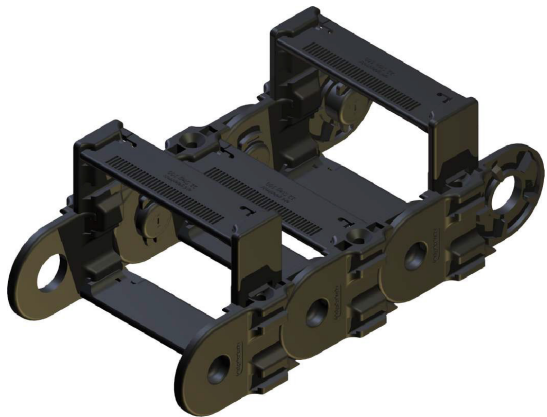

## PKK 113, 123, 143, 213, 223, 243, 313, 323, 343, 513, 523

The PKK with extension stays in the inner radius. Suitable for low speeds these stays create additional space. The extension stays can be arranged in the outer radius or in other combinations as per optional drawing. The extension stays are available in two lengths.



## PKK 125, 225, 325, 525

The closed designs offer optimum protection of the lines against chips or against UV radiation. The covers can be opened in the inner or outer radius. The closed types may also be subsequently created from the standard version.

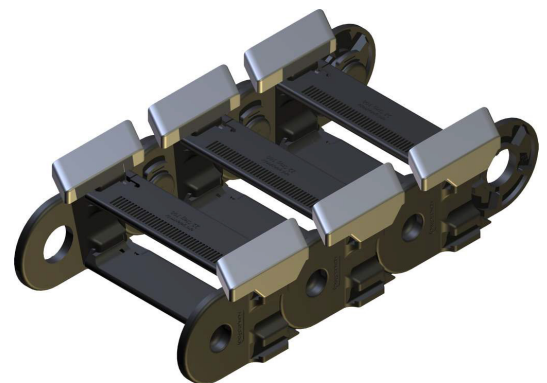

## PKK 115, 215, 245, 315, 345, 515

Without T-slot on the outside, the closed types achieve a good visual effect with their flat sides and a smaller width.

## PKK 228, 328, 528

The PKK 128, 228 and 328 with sliders are designed for gliding arrangements (long travel distances) and are fitted with stays in each link. The sliders are mounted in the inner radius of the cable carrier and have a very low coefficient of friction ( $\mu = 0.20$  to  $0.25$ ). The sliders can also be installed afterwards. At low stroke rates and low speeds ( $<1\text{m/s}$ ) sliders are not necessary. The smallest radius of each dimension of the PKK is not suitable for sliders.

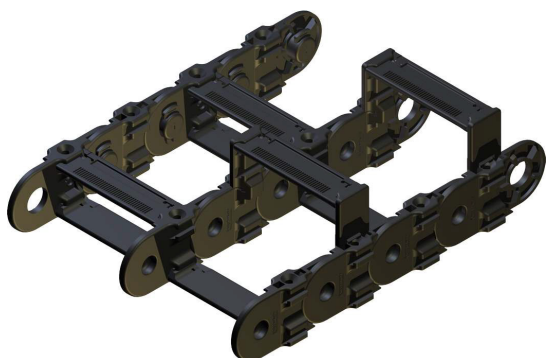

## MULTIBAND CABLE CARRIERS

Multiband cable carriers can be created by attaching additional link bands. These are assembled through stays at standard cable carriers (see assembly, except PKK with smooth exteriors).

# PKK SIZES



	<b>PKK 120</b> height 25	inner height 16
	<b>PKK 140</b> height 40	inner height 30
	<b>PKK 220</b> height 50	inner height 34
	<b>PKK 240</b> height 60	inner height 44
	<b>PKK 320</b> height 75	inner height 51
	<b>PKK 340</b> height 85	inner height 61
	<b>PKK 520</b> height 104	inner height 80

# PKK SAPRE PARTS

- 1 PKK 220 link
- 2 PKK 210 link
- 3 SD/Z (universal flange connector pivot)
- 4 SD /B (universal flange connector drilling)
- 5 PKK 220 connector link short (drilling)
- 6 PKK 220 connector link short (pivot)
- 8 spreader
- 9 22 stay 100
- 10 22 ASI 100 (inner cover)
- 11 22 ASA 100 (outer cover)
- 12 cover holder
- 13, 13a PZ (plastic divider)
- 14 PT 55/PT 75 (telescopic horizontal divider) extension
- 15 stay long
- 16 extension stay short
- 17 slider R100
- 18 damping element
- 19 band holder
- 20 ladder stay
- 23 horn stay 220
- 24 PZ fork stay
- 25 PZ fork stay short
- 26 Snap (optional)

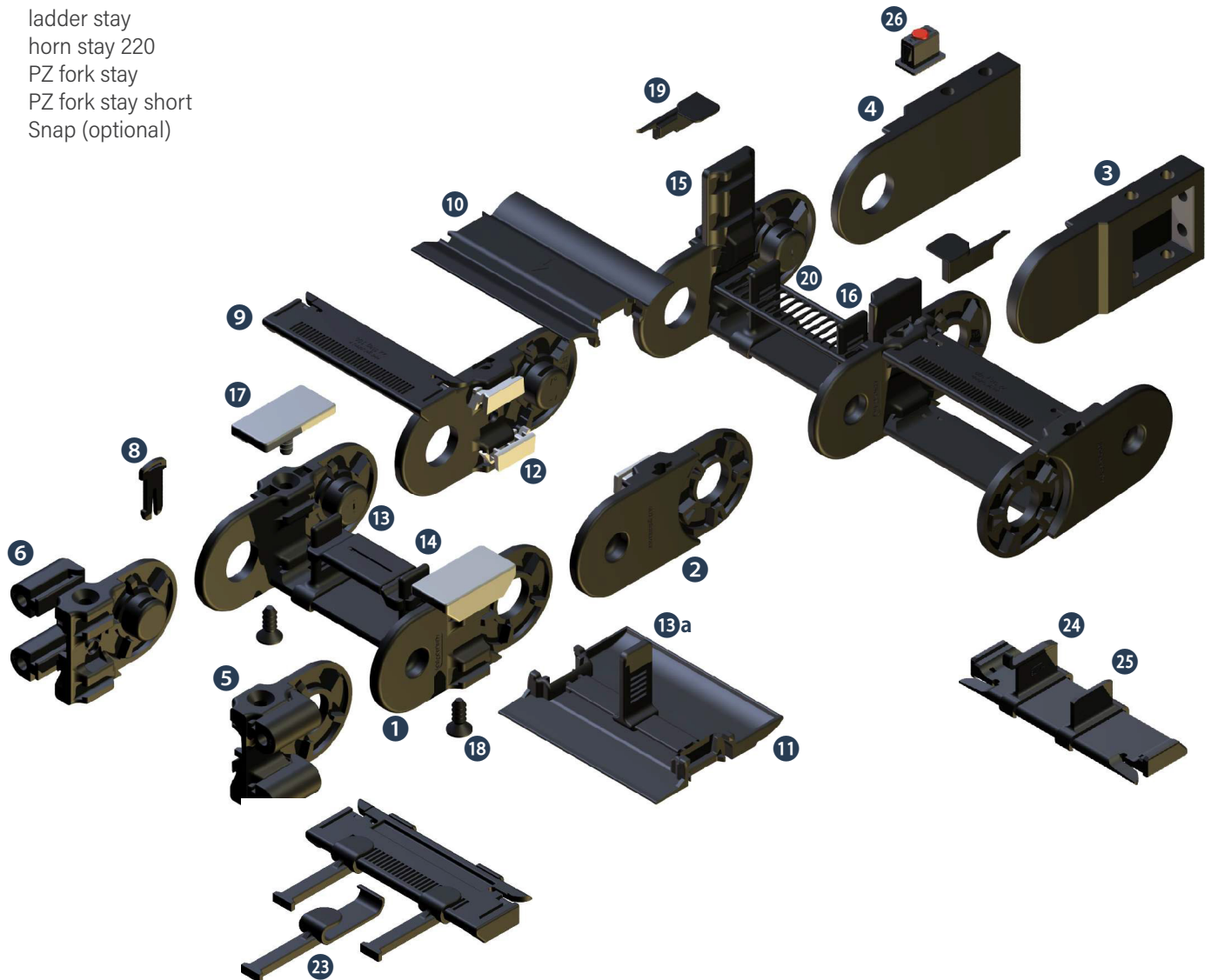

# PKK ASSEMBLY

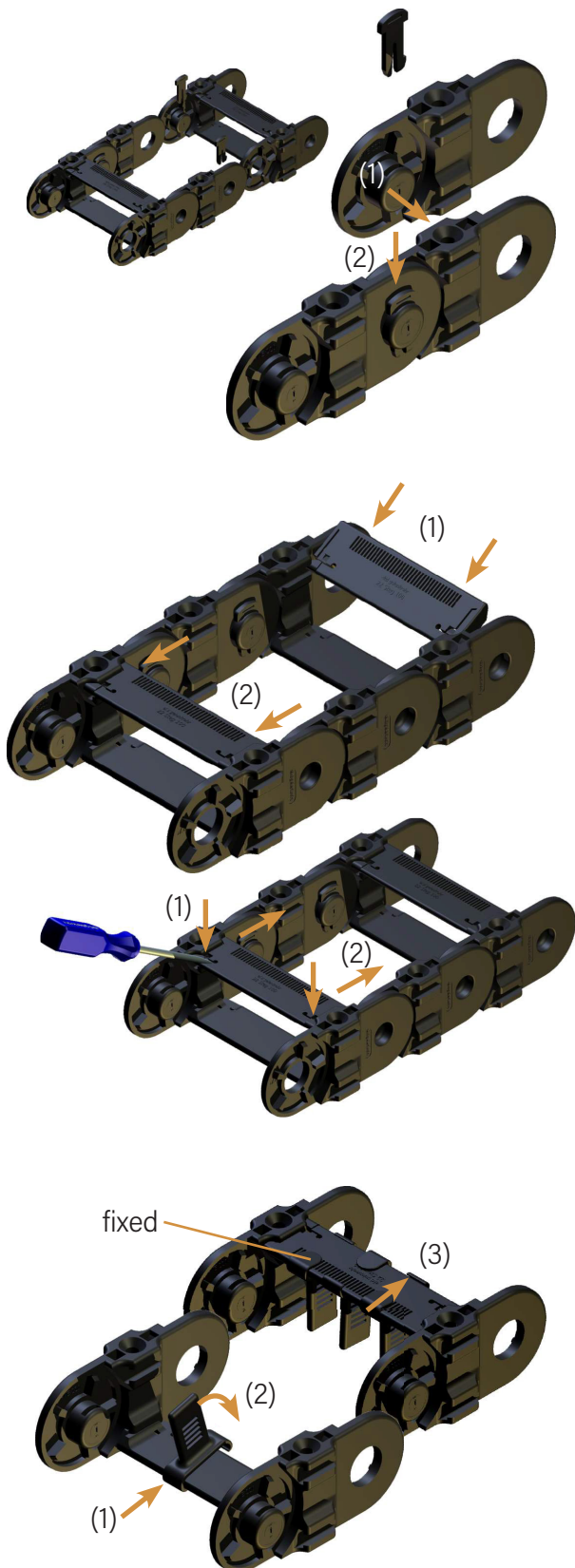

## PACKAGING

Cable carriers are supplied in transport friendly packaging. When removing the packaging and during removal of the cable carrier or parts of it, ensure that the cable carriers are free of torsion and tension, to avoid mechanical damage.

## LENGTHENING AND SHORTENING

Lengthening of the cable carrier is done by fitting of cable carrier pieces or links (1) and lock with spreader (2). To shorten the spreader is disengaged and removed, then the piece of chain removed. Alternatively first link strands may be mounted and then stays assembled. For the PKK the opposite link strands are rotated by 180° and arranged with the pivot on the inner chain.

## STAY ASSEMBLY

The stays with the locking tabs are put in the T-guide of the link (1) and push until it clicks into the guides (2). The stays can be positioned initially in the T-guide and will be engaged in one swoop (plastic hammer or similar) in the final position.

## STAY DISASSEMBLY

The lock tongue of the stays are unlocked with a screwdriver (1) and the stays pushed out with light pressure to the front of the T-slot (2). For medium and larger series (from PKK220) the stays can be unlocked with a light hit on the lock tongue (plastic hammer or similar) and then ejected.

## PLASTIC DIVIDER PZ (VERTICAL)

The PZ will be placed in the designated position on the stay (1) and engaged (2). The PZ can be mounted fixed or movable. The dismantling is done by unlocking (3) and removal of the PZ.



# PKK ASSEMBLY

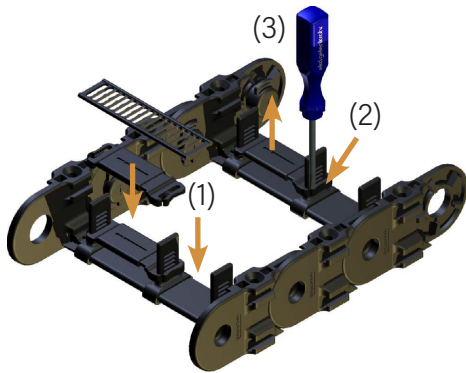

## TELESCOPIC DIVIDER AND LADDER DIVIDER

The telescopic horizontal divider and ladder stay horizontally pushed onto the plastic divider (PZ) and engaged in the designated height (1). The disassembly is done with a screwdriver through pull (2) and removal (3).

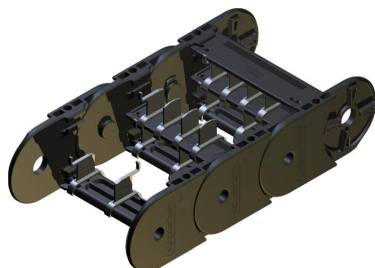

## PZ FORK STAYS

The fork stays allow in combination with an additional stay a horizontal separation and several vertical separations. Fork stays are clipped upon the stays like plastic divider PZ.

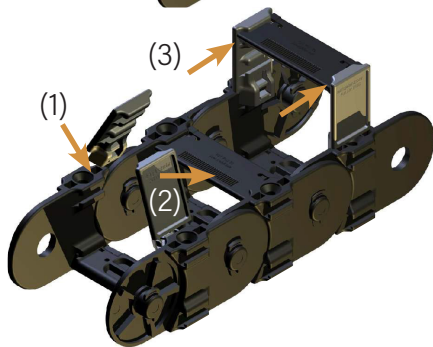

## EXTENSION STAYS

The extension stays are pushed onto the link guides (1) and pivoted until it clicks (1). Then the stays are pushed into the guides until it clicks (3).

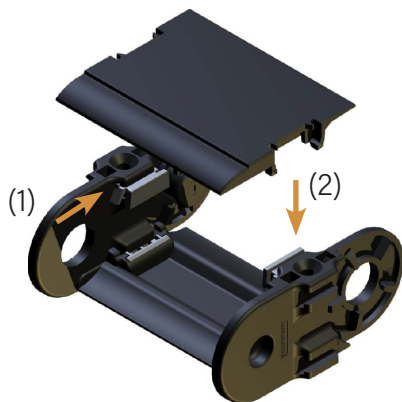

## COVERS

Before installing covers (ASA/ASI) first segment holder have to be pushed in the T-slot of the links (1). Then the covers can be plugged in (2). Covers and segment holder snap in the end position.

The covers are marked with arrows, to avoid wrong assembly direction. Covers for the outer radius are equipped with holders for divider (PZ).



During assembly, ensure the correct overlap of the covers and that the covers are engaged on all four locking points. The inner radius covers (ASI) of length 200 mm of the PKK 215, 225, 245 and 300 mm of the PKK 315, 325, 345 are designed with a pivot on one side. The cover has to be pushed into the T-slot of the link on its pivot side (1) and can swing to close or open (2). For that the cover holder has to be unlocked (see disassembly).

# PKK ASSEMBLY

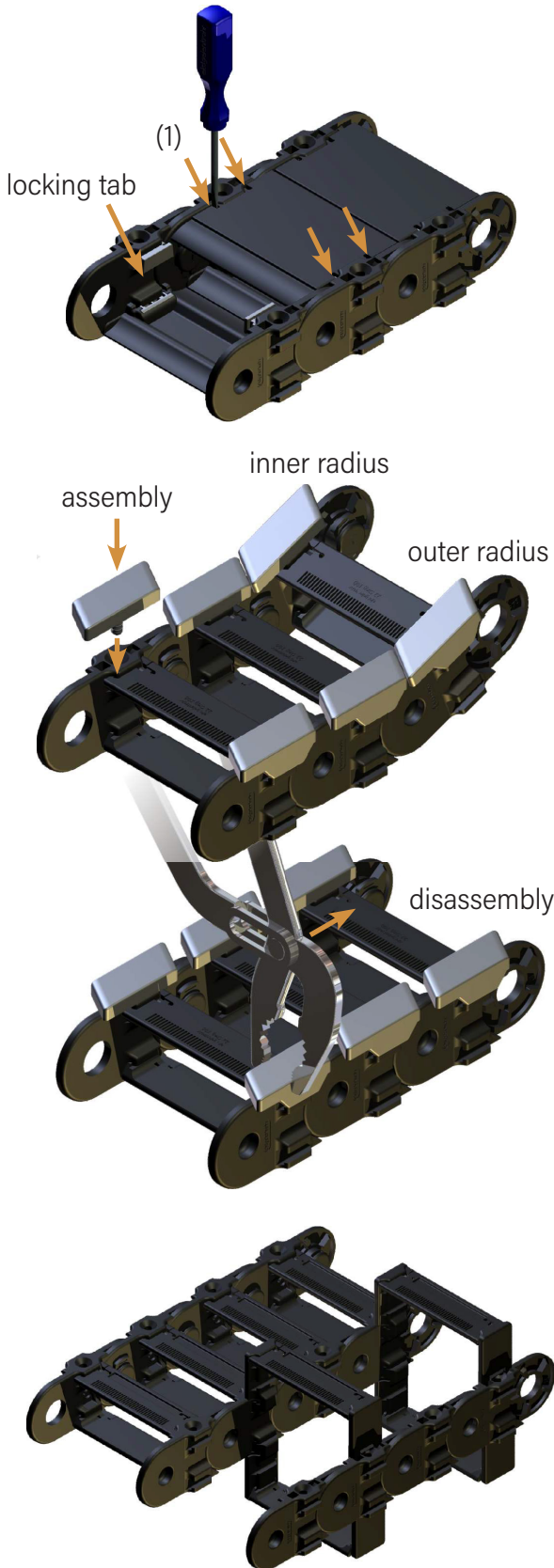

The dismantling of the covers is done by unlocking and lifting out. These are done one by one at a time with the 4 locking tongues on the segment holders using a screwdriver (1), then the cover is easy to raise. With two release tools all four locking tongues can be done at once and the cover removed.

**Attention:**  
*The release tools can only be resolved if covers are dismantled (by lateral withdrawal)*

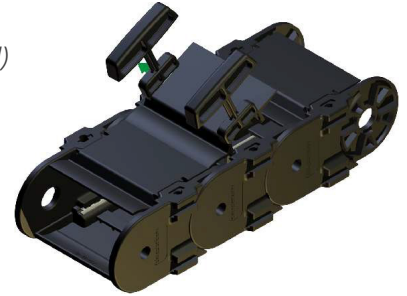

Covers with lengths 200 mm and 300 mm of the PKK 225 and 325 are equipped with a pivot on one side. These covers opening mechanism is deactivated on one side. The covers can be swiveled.

## SLIDERS

The sliders are mounted in the inner radius of the cable carrier. The minimum bend radius in each PKK size can not be fitted with sliders.

During assembly of the sliders be aware of the following:  
 The sliders must be conditioned (water content min. 1%, overnight storage in water at room temperature or 2 hours at 80° C).

Heat the slider just before mounting in a water bath.  
 Avoid impact load.

The dismantling is carried out with channel lock pliers as shown and unlock slider by turning it to the outer side.

## MULTIBAND Cable carriers

Multiband cable carriers can be created by attaching additional link strands. These are attached to existing cable carriers by additional stays.

By combining with extension stays large hoses or other additional components may be carried.

# PKK ASSEMBLY

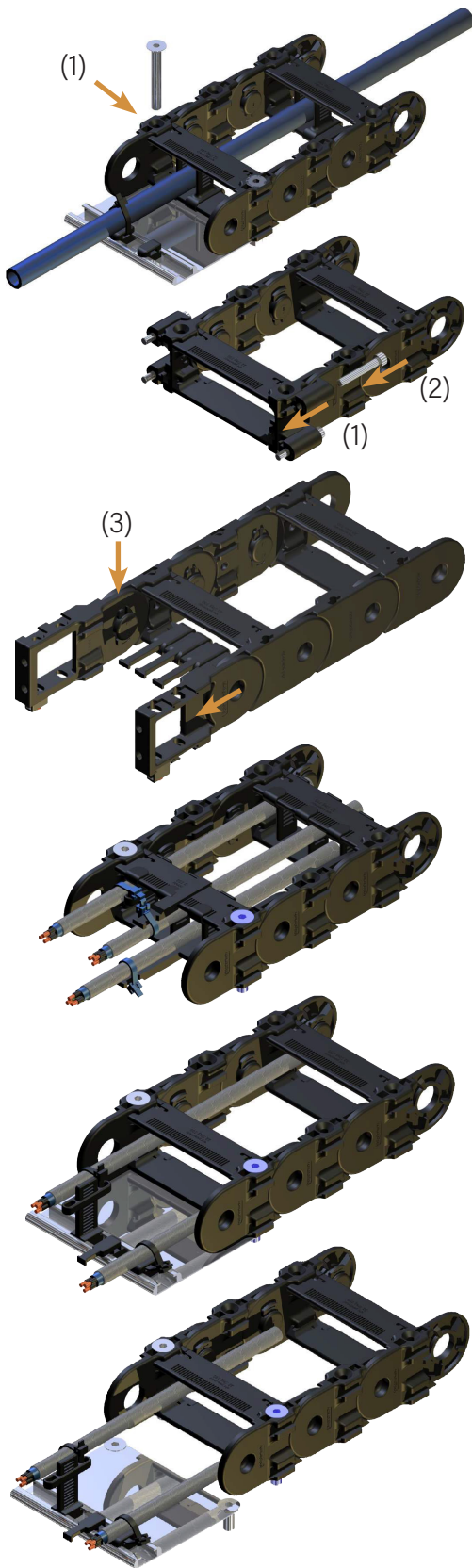

## MOUNTING THE CABLE CARRIER

All of our plastic cable carriers are equipped with the integrated connector (1). When using integrated strain relief, no additional components are needed. Provision for the combined strain relief, the anchor profile has to be screwed with the first link in the chain. Separate strain relief can be subsequently mounted.

## HEADSIDE MOUNTING

Optionally, the attachment can be made with flange connectors or universal connectors. The flange connectors are mounted in the T-slots of short connectors links until locking (1). The cable carriers can be attached through four flange connectors (2). The SD connectors are mounted like the links with the spreader (3) and provide universal connection options, as an example with snap for fast and tool-less assembly.

## STRAIN RELIEFS

With long travel distances and high speeds the lines at one end of the cable carrier, preferably on the moved driver, are attached to strain reliefs. The distance of strain relief to the bending area depends on the particulars of the line manufacturer.

## INTEGRATED STRAIN RELIEF

In this space-saving type strain reliefs are directly mounted on the vertical divider (PZ) of the first link of the cable carrier. The mounting direction of the PZ must be chosen so that tension directed on the chain can not unlock the divider. In order to avoid premature line wear caused by dynamic loads a small extra chain length is recommended.

## COMBINED STRESS RELIEF

The combined strain relief combines the advantage of sufficient distance from the strain relief to the bending line areas provided by a simple and space-saving installation of the integrated strain relief. The anchor profile is fitted to the drilling dimensions of the cable carrier (integrated connectors) and attached to this. The lateral insertion and extraction of strain relief elements is possible at any time.

## SEPARATE STRESS RELIEF

The separate strain relief is recommended for high dynamic loads and large line diameters. A sufficient distance from the strain relief to the chain is easy to implement.



# SLE OVERVIEW

## FEATURES

- Optimized Support and Organization: Customize cable/hose arrangements based on application needs with a variety of stay distribution options
- Easy Assembly/Disassembly: The fast stay assembly and disassembly design simplifies maintenance and adjustments, minimizing downtime
- Quick Length Adjustment: Enjoy quick and easy length adjustment to accommodate varying cable lengths and configurations, providing flexibility for your setup
- Shroud Pivot Mechanics Protection: A protective shield is designed around the pivot mechanisms of the cable carrier to safeguard against external elements such as dirt, debris, and contaminants
- Travel Distance: The maximum distance of travel is determined by the arrangement and additional weight of the lines, but normal arrangement provides a maximum travel of double the free carrying length; travel distances up to 100 meters are possible
- Travel Speed and Acceleration: Both standard and stainless steel designs are limited to 1m/s; while there are no specific limits on acceleration, high line weights may impose some limitations due to tensile stresses.
- Wide Temperature Range: Long term temperature limits are between -20°C and 600°C (-4°F and 1112°F). For stainless the limits are -40°C and 600°C (-40°F and 1112°F).



## APPLICATIONS

- Machine tools
- Mills
- Spacial machinery
- Wood processing industry
- Conveying and lifting equipment

# SLE OVERVIEW

## LOAD DIAGRAM

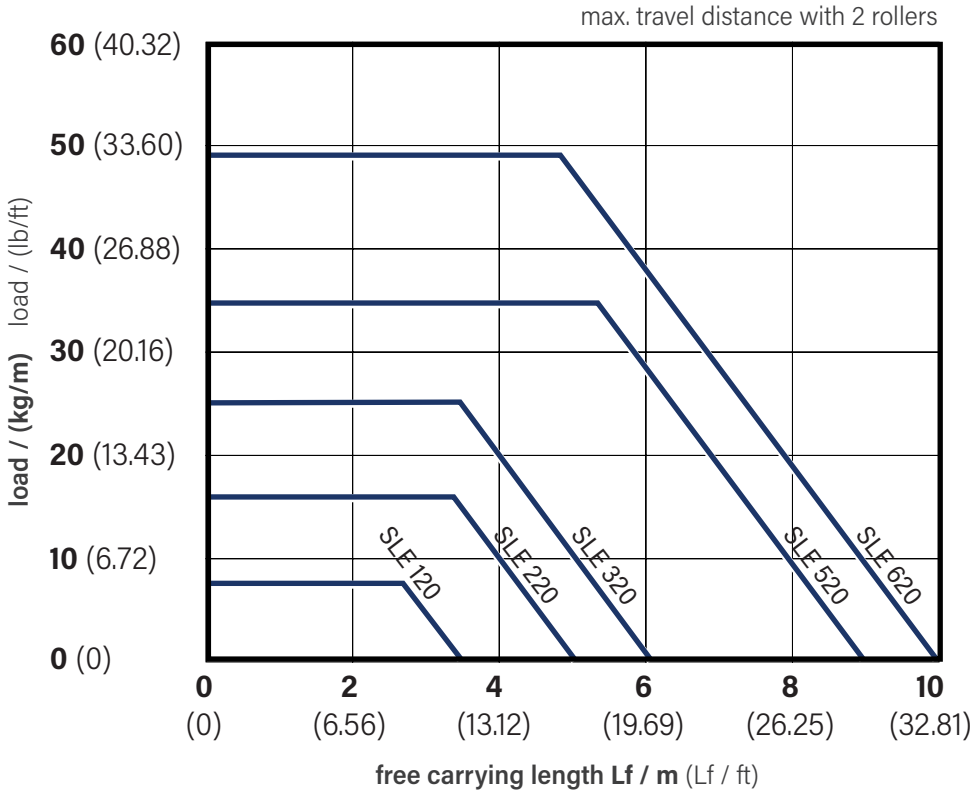

## SLE ORDER EXAMPLE

**SLE 120/100 x 2050/100**

(type/radius x length/stay width)

See pages 35-36 for SLE types and stay widths

## TEMPERATURE

Long term temperature limits are between  $-20^{\circ}\text{C}$  and  $600^{\circ}\text{C}$  ( $-4^{\circ}\text{F}$  and  $1112^{\circ}\text{F}$ ).

For stainless the limits are between  $-40^{\circ}\text{C}$  and  $600^{\circ}\text{C}$  ( $-40^{\circ}\text{F}$  and  $1112^{\circ}\text{F}$ ).

## TRAVEL DISTANCE

The maximum range of travel is determined by the arrangement and the additional weight (line weight). At normal arrangement the maximum travel is double the free carrying length. Support rollers or similar constructive steps can increase this value. Travel distances up to 100 meters are possible.

## TRAVEL SPEED

The standard and stainless steel designs are limited at 1 m/s.

## ACCELERATION

There are no limits for the accelerations, in general. Limits may occur through the tensile stresses at high line weights.



# SLE DIMENSIONS

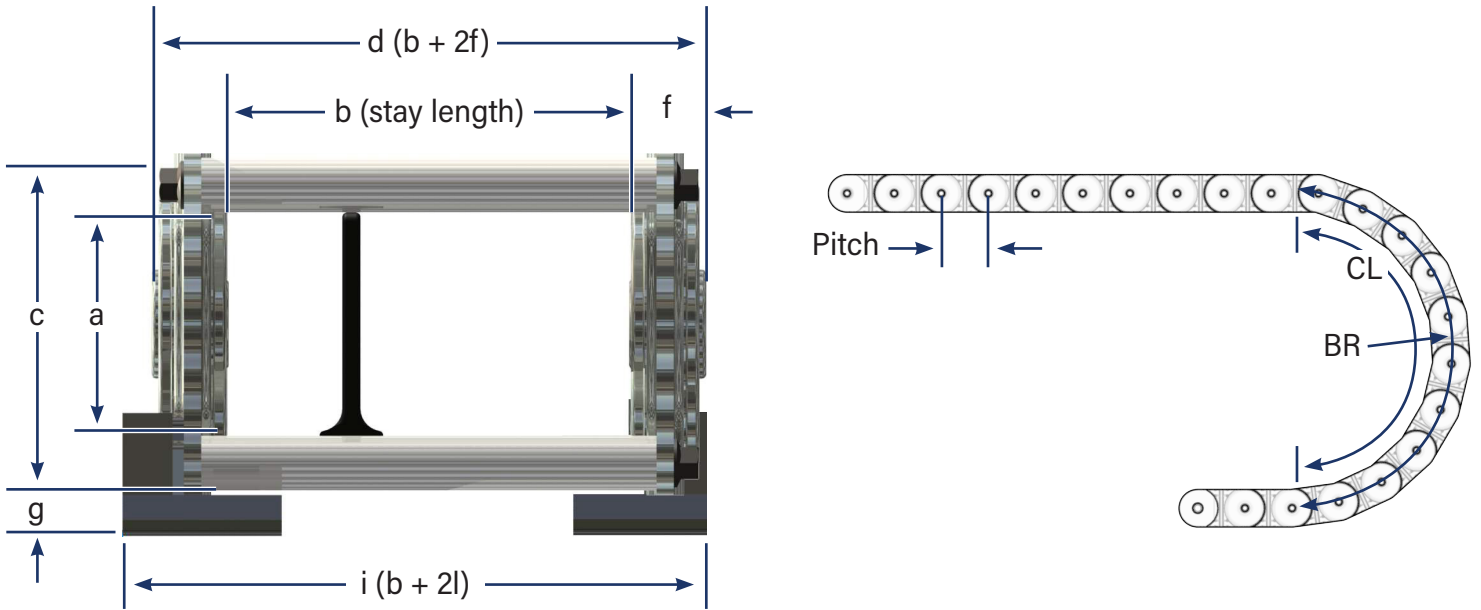

## SLE CONNECTORS

Special connectors with custom dimensions available.

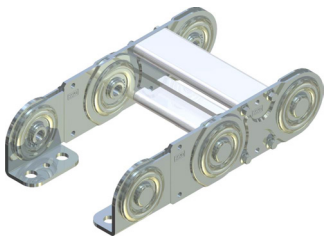

**Normal:** Outer Radius

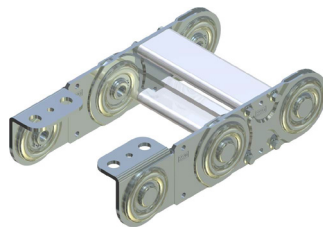

**E:** Inner Radius

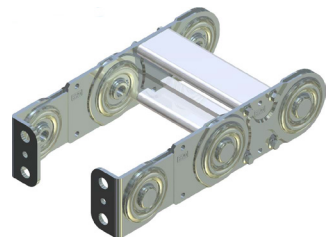

**A**

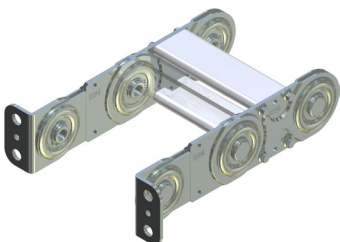

**B**

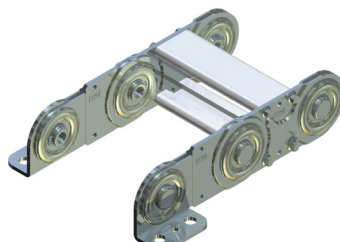

**C**

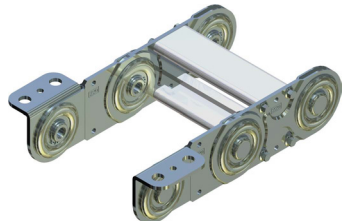

**D**

# SLE DIMENSIONS

All dimensions shown in inches and (mm). See page 36 for dimension b (stay lengths).

SLE Type	Pitch	a	c	f	g	l	BR	H	CL	Weight (KG/M)
<b>120, 121, - , 128</b>	1.97 (50)	0.79 (20)	1.38 (35)	0.24 (6)	0.28 (7)	0.35 (9)	2.36 (60)	6.10 (155)	11.35 (288.4)	2.3
	1.97 (50)	0.79 (20)	1.38 (35)	0.24 (6)	0.28 (7)	0.35 (9)	3.94 (100)	9.25 (235)	16.30 (414.0)	2.3
	1.97 (50)	0.79 (20)	1.38 (35)	0.24 (6)	0.28 (7)	0.35 (9)	5.91 (150)	13.19 (335)	22.48 (571.0)	2.3
	1.97 (50)	0.79 (20)	1.38 (35)	0.24 (6)	0.28 (7)	0.35 (9)	9.84 (250)	21.06 (535)	34.84 (885.0)	2.3
<b>220, 221, 225, 228</b>	2.95 (75)	1.22 (31)	1.97 (50)	0.31 (8)	0.35 (9)	0.51 (13)	3.94 (100)	9.84 (250)	18.27 (464.0)	4.3
	2.95 (75)	1.22 (31)	1.97 (50)	0.31 (8)	0.35 (9)	0.51 (13)	5.91 (150)	13.78 (350)	24.45 (621.0)	4.3
	2.95 (75)	1.22 (31)	1.97 (50)	0.31 (8)	0.35 (9)	0.51 (13)	7.87 (200)	17.72 (450)	30.63 (778.0)	4.3
	2.95 (75)	1.22 (31)	1.97 (50)	0.31 (8)	0.35 (9)	0.51 (13)	9.84 (250)	21.65 (550)	36.81 (935.0)	4.3
	2.95 (75)	1.22 (31)	1.97 (50)	0.31 (8)	0.35 (9)	0.51 (13)	11.81 (300)	25.59 (650)	42.99 (1092.0)	4.3
<b>320, 321, 325, 328</b>	3.94 (100)	1.93 (49)	2.95 (75)	0.43 (11)	0.43 (11)	0.71 (18)	5.91 (150)	14.76 (375)	26.42 (671.0)	7.9
	3.94 (100)	1.93 (49)	2.95 (75)	0.43 (11)	0.43 (11)	0.71 (18)	7.87 (200)	18.70 (475)	32.60 (828.0)	7.9
	3.94 (100)	1.93 (49)	2.95 (75)	0.43 (11)	0.43 (11)	0.71 (18)	9.84 (250)	22.64 (575)	38.78 (985.0)	7.9
	3.94 (100)	1.93 (49)	2.95 (75)	0.43 (11)	0.43 (11)	0.71 (18)	11.81 (300)	26.57 (675)	44.96 (1142.0)	7.9
	3.94 (100)	1.93 (49)	2.95 (75)	0.43 (11)	0.43 (11)	0.71 (18)	15.75 (400)	34.45 (875)	57.32 (1456.0)	7.9
<b>520, 521, 525, 528</b>	4.92 (125)	2.68 (68)	3.94 (100)	0.59 (15)	0.51 (13)	0.79 (20)	7.87 (200)	19.69 (500)	34.57 (878.0)	15.1
	4.92 (125)	2.68 (68)	3.94 (100)	0.59 (15)	0.51 (13)	0.79 (20)	9.84 (250)	23.62 (600)	40.75 (1035.0)	15.1
	4.92 (125)	2.68 (68)	3.94 (100)	0.59 (15)	0.51 (13)	0.79 (20)	11.81 (300)	27.56 (700)	46.93 (1192.0)	15.1
	4.92 (125)	2.68 (68)	3.94 (100)	0.59 (15)	0.51 (13)	0.79 (20)	15.75 (400)	35.43 (900)	59.29 (1506.0)	15.1
	4.92 (125)	2.68 (68)	3.94 (100)	0.59 (15)	0.51 (13)	0.79 (20)	19.69 (500)	43.31 (1100)	71.65 (1820.0)	15.1
<b>620, 621, 625, 628</b>	6.89 (175)	4.65 (118)	5.91 (150)	0.59 (15)	0.51 (13)	0.79 (20)	9.84 (250)	25.59 (650)	44.69 (1135.0)	19.3
	6.89 (175)	4.65 (118)	5.91 (150)	0.59 (15)	0.51 (13)	0.79 (20)	11.81 (300)	29.53 (750)	50.87 (1292.0)	19.3
	6.89 (175)	4.65 (118)	5.91 (150)	0.59 (15)	0.51 (13)	0.79 (20)	15.75 (400)	37.40 (950)	63.23 (1606.0)	19.3
	6.89 (175)	4.65 (118)	5.91 (150)	0.59 (15)	0.51 (13)	0.79 (20)	19.69 (500)	45.28 (1150)	75.59 (1920.0)	19.3
	6.89 (175)	4.65 (118)	5.91 (150)	0.59 (15)	0.51 (13)	0.79 (20)	23.62 (600)	53.15 (1350)	87.95 (2234.0)	19.3

# SLE STAY LENGTH

All dimensions shown in inches and (mm).

SLE Type	b (Stay Length) offered in steps of 0.04" (1 mm)	Plastic Inserts Ø inch (mm)
<b>120, 121, - , 128</b>	1.57 (40) — 31.50 (800)	-
<b>220, 221, 225, 228</b>	1.97 (50) — 35.43 (900)	0.39 (10), 0.59 (15), 0.79 (20), 0.98 (25), 1.18 (30)
<b>320, 321, 325, 3281</b>	2.36 (60) — 39.37 (1000)	0.39 (10), 0.59 (15), 0.79 (20), 0.98 (25), 1.18 (30), 1.38 (35), 1.57 (40), 1.77 (45), 1.97 (50)
<b>520, 521, 525, 5281</b>	2.76 (70) — 47.24 (1200)	0.39 (10), 0.59 (15), 0.79 (20), 0.98 (25), 1.18 (30), 1.38 (35), 1.57 (40), 1.77 (45), 1.97 (50)
		2.17 (55), 2.36 (60), 2.56 (65), 2.76 (70)
<b>620, 621, 6252), 6281</b>	3.94 (100) — 47.24 (1200)	-

# SLE TYPES

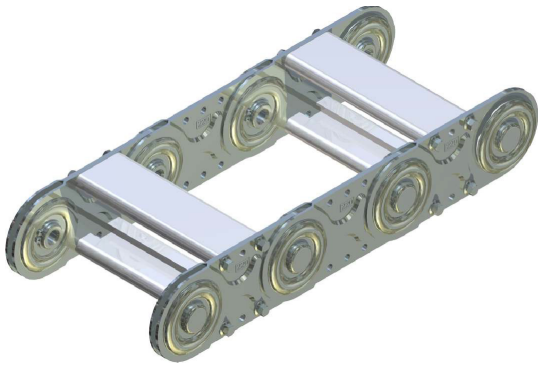

## SLE 120, 220, 320, 520, 620

The standard type is built with stays in every second chain link. The steel link cable carriers can be opened in the inner and in the outer bending radius.

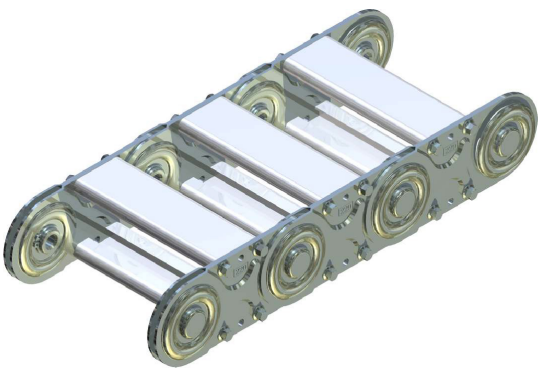

## SLE 121, 221, 321, 521, 621

These designs are made with stays in each link. This increases the lateral stability and improves the guiding particularly of smaller diameter lines.

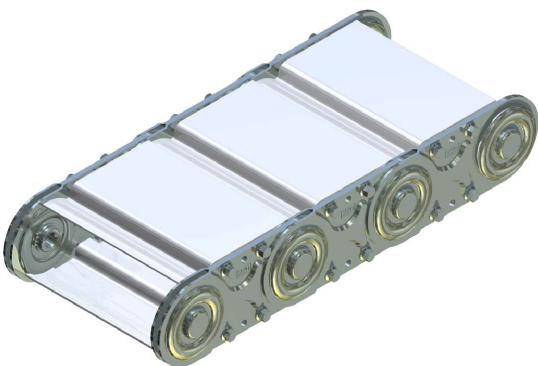

## SLE 225, 325, 525, 625

The closed types offer optimum protection of the lines against dust and cuts or other environmental influences. At higher temperatures the Silver Star covers provide excellent protection. The closed types also may be built to replace the standard version stay.

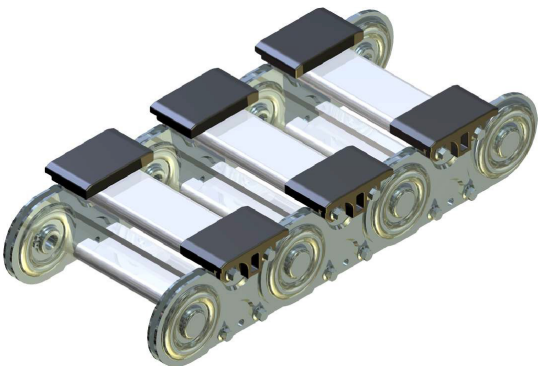

## SLE 128, 228, 328, 528, 628

These types are suitable for long travel, the upper strand slides on the lower strand. For greater stability these cable carriers are built with stays in each link. The cable carriers are fitted with sliders, which have a very low coefficient of friction ( $\mu = 0.20$  to  $0.25$ ). After reaching the wear limit the slider can be renewed and the cable carrier will continue.

# SLE TYPES

Compared to standard chains, the SLE series is characterized by the fact that the sturdy aluminum profile can be steplessly adapted to the requirements. Stay lengths of up to 1500 mm can be provided. The subdivision of the interior satisfies every requirement and guarantees optimized cable protection, even at very high accelerations and travel speeds. For extreme applications, the variants SLA, SLS and SLE should be preferred, since these offer optimized cable guiding. In the case of high speed and acceleration a multi-layer arrangement of the cable should be avoided.

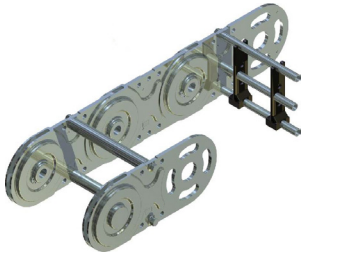

## SLA - ALUMINUM T-PROFILE/ALUMINUM SLOT PROFILE

The SLA is a highly customized and robust cable carrier, which is chosen primarily for larger dimensions. The stays are milled in accordance with the requirements of the user with individual hole patterns.

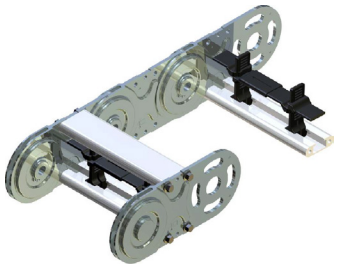

## SLE - PLASTIC INSERTS/PLASTIC SLOT PROFILE

The SLE ensures a perfect guide at high speeds and almost excludes errors during installation of the lines. With this design the hole pattern of the stays can be adjusted accurately to the needs of the lines. Plastic inserts are available in a 5 mm grid. The plastic slot-profile can be ordered to suit special requirements.



## SLS - FOAM SLOT PROFILE

For limited installation space, the SLS are used. Again, the optimal guiding of the lines at high speeds and acceleration is ensured. Well known automotive manufacturers have used this type for years with the best experiences. All lines lie in the neutral axis of the cable carrier.

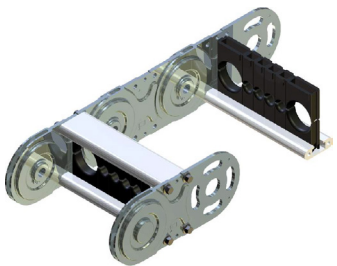

## SLP - PLASTIC DIVIDER PZ + OTHERS

For space reasons, the SLP can be selected. This inexpensive design allows the guiding of large amounts of cable. The highly variable distribution possibility through small steps of (3mm) in height, plus the telescopic divider (PT) allows maximum space for all needs, even when changes in cable diameters are required.

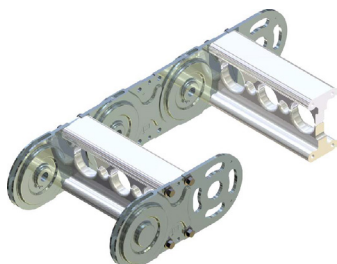

## SLR - PIPE OR ROLL STAYS

The SLR is manufactured only upon request. The pipe stay allows special material combinations, such as the exclusion of aluminum or the use of stainless steel and brass. The roll bar has advantages particularly for heavy lines with high friction and wear in terms of durability of the cables and hoses: Relative movements on the cable carrier are compensated by the rolling motion of the stays.



# SLE SIZES



## SLE 120

**height** 35  
**inner height** 20

**width** 52 ... 812  
**inner width** 32 ... 792  
**stay length** 40 ... 800

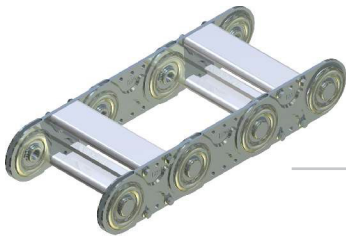

## SLE 220

**height** 50  
**inner height** 31

**width** 66 ... 916  
**inner width** 38 ... 888  
**stay length** 50 ... 900

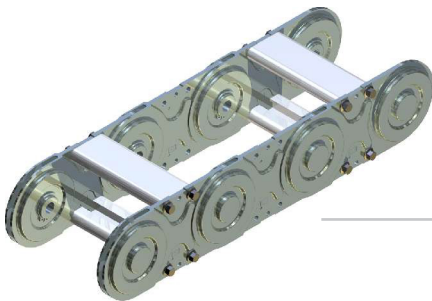

## SLE 320

**height** 75  
**inner height** 49

**width** 80 ... 1020  
**inner width** 50 ... 990  
**stay length** 60 ... 1000

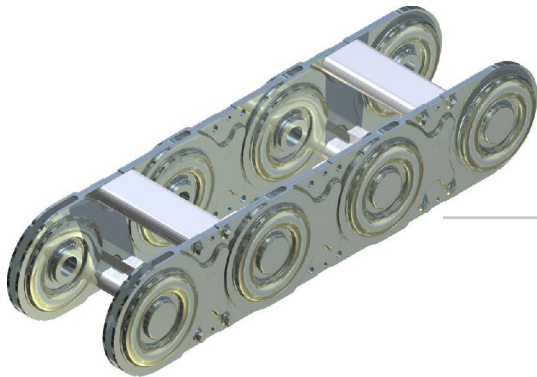

## SLE 520

**height** 100  
**inner height** 68

**width** 98 ... 1028  
**inner width** 54 ... 1184  
**stay length** 70 ... 1500

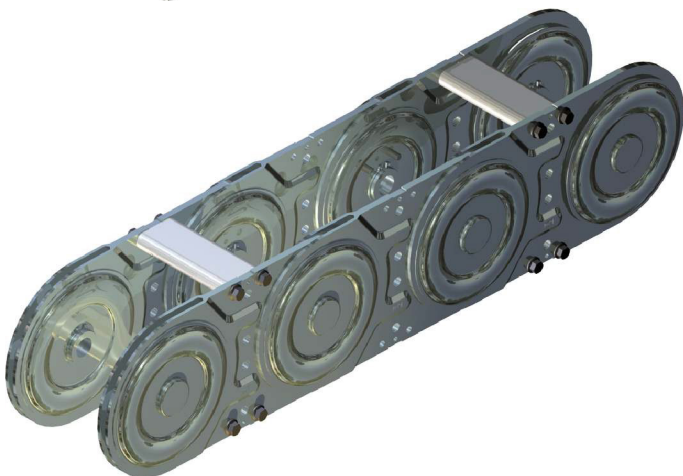

## SLE 620

**height** 150  
**inner height** 118

**width** 128 ... 1228  
**inner width** 84 ... 1184  
**stay length** 100 ... 1500

# SLE PARTS

- 1 link
- 2 connector link single
- 3 connector link double
- 4 connector angle
- 5 flange bolt
- 6 radius bolt
- 7 cover plate
- 8 retaining ring
- 9 aluminum C-profile
- 10 serrated screw
- 11 plastic (vertical) divider
- 12 outer cover
- 13 distance filler

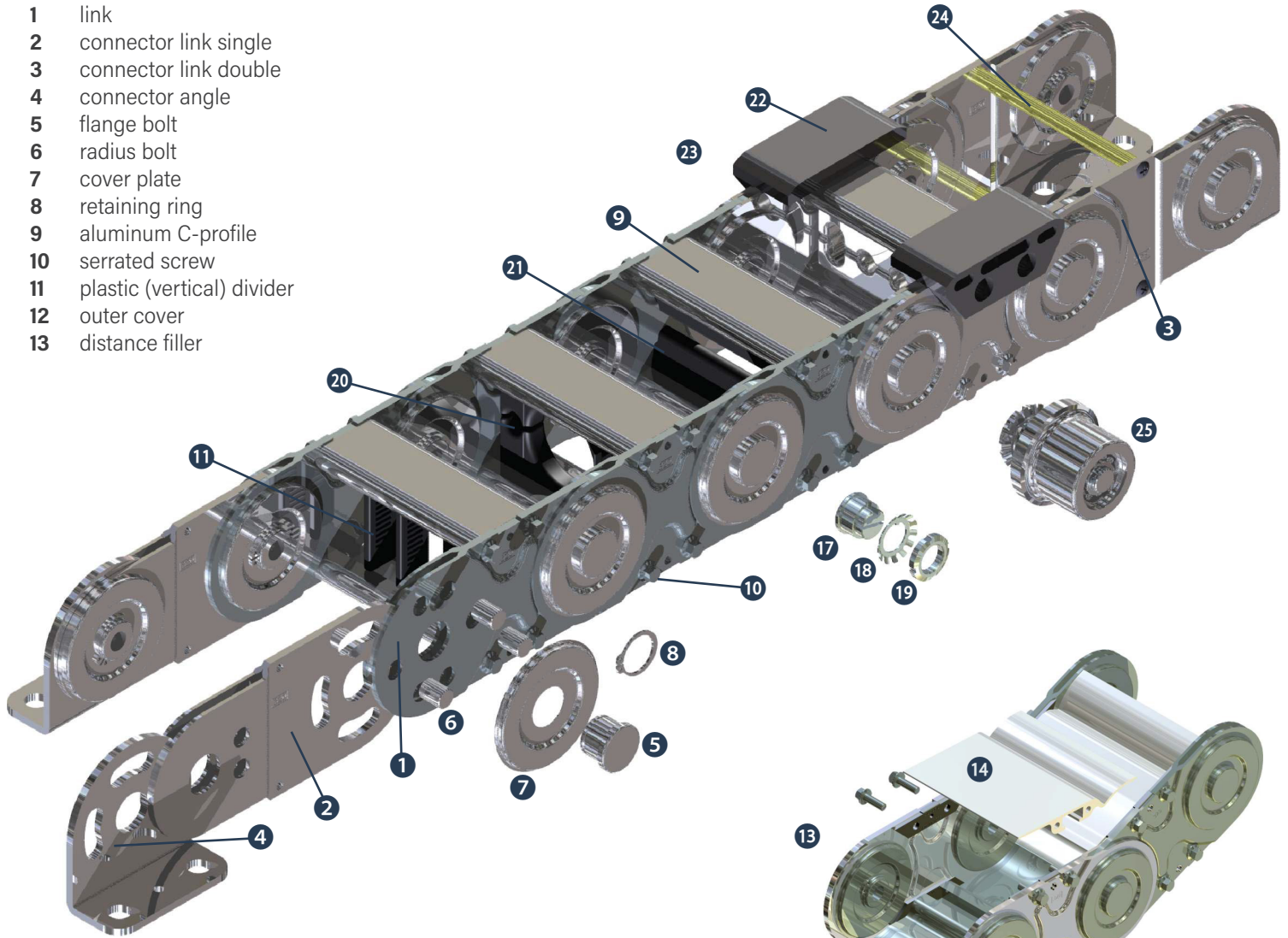

- 14 inner cover
- 15 band holder
- 16 band (steel/stainless steel)
- 17 threaded bolt
- 18 lock washer
- 19 locknut
- 20 plastic inserts
- 21 foam
- 22 slider
- 23 aluminum-T-profile
- 24 pipe stay
- 25 flange rollers

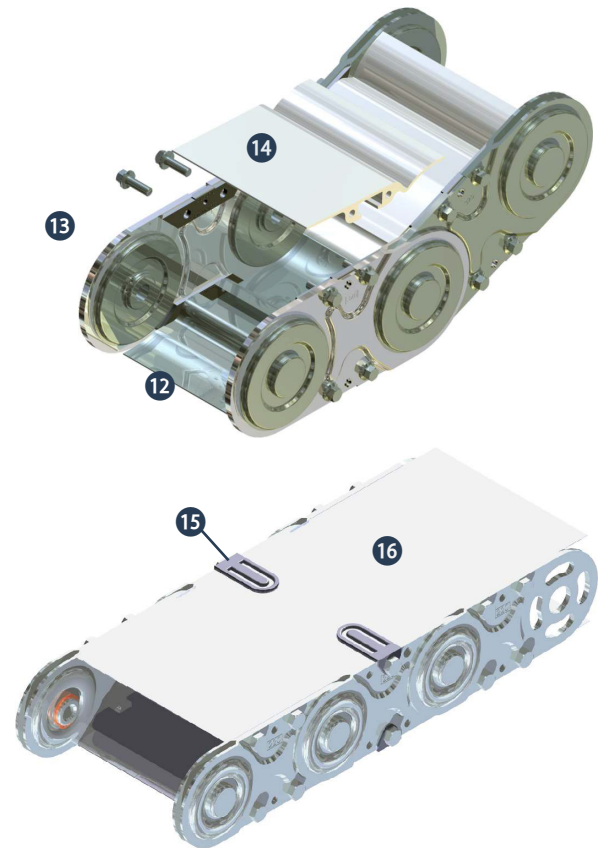

The use of steel chains with steel bands (16) is limited to cable carriers with a maximum length of 6 m and stay length of 600 mm.

# SLE ASSEMBLY

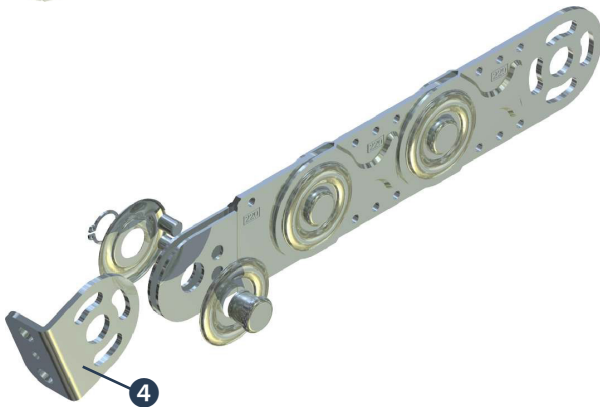
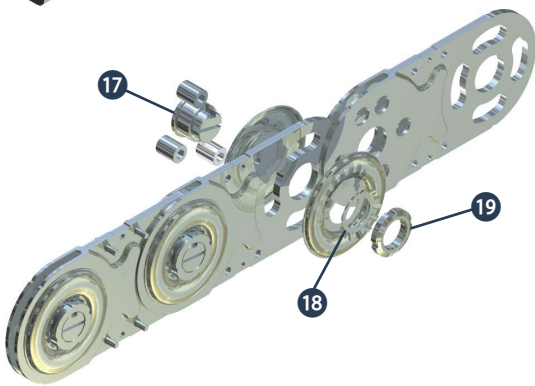
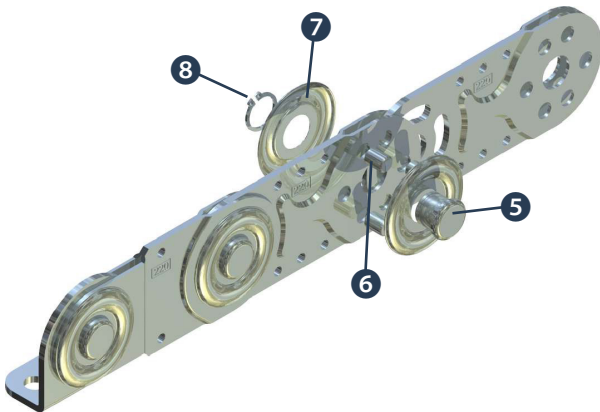

## PACKAGING

When removing the packaging and moving the cable carriers or parts of them, ensure that the cable carriers are free of torsion and tension to avoid mechanical damage.

## LENGTHENING OR SHORTENING

**If cable carriers are delivered in pieces, proceed with the installation as follows:**

Push the link together (1) and insert the flange bolts (5) with a shroud (7) in the carrier outside. Then build the radius by inserting the radius bolts (6) (see chart for correct radius). Finally put on the inner shroud (7) and fit the retaining ring (8). Roll the cable carrier to check that the radius is correct throughout its length.

**Shortening in the reverse order:**

Loosen the retaining rings (8), pull out the flange bolts (5), lifting the shroud (7), pull the radius bolts (6) and remove the links (1). Cable carriers with threaded bolts instead of the retaining rings (8), first unlock the locking plates (18) to solve the locknuts (19). Thereafter, the threaded bolts (17) and pins (6) can be removed and taken from the links (1).

## IMPLEMENT THE CONNECTOR ANGLE

The connector angles (4) are orientated to the outer radius and to the carrier center (normal end mounted). By loosening the retaining rings (8), drag the flange bolts (5), lift off the shroud (7) and pull the radius bolts (6) the connector angles (4) can be disassembled and placed in a different position.

## BENDING RADIUS

Loosen the retaining rings (1) and lift off the shrouds (7). Implement the radius bolts (6) according to table (page 20). Then mounting the shrouds (7) and retaining Rings (1). The detachable bolts position for the different radii can be found engraved on the double connector links (3).

# SLE ASSEMBLY

## ASSEMBLY OF RADIUS BOLTS

All dimensions shown in inches and (mm).

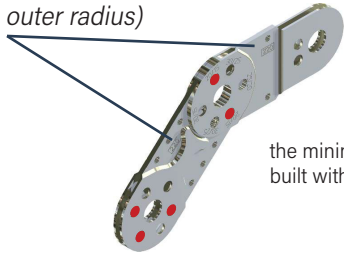
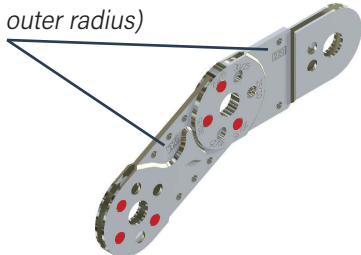
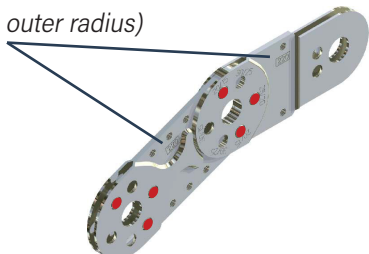
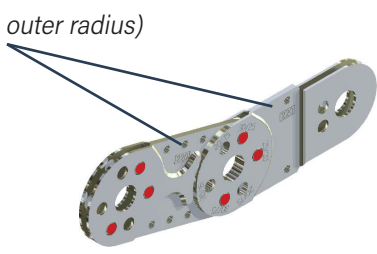
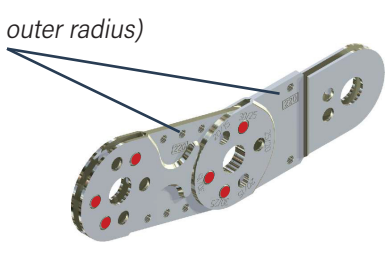
SLE	120	220	320	520	620	
radius	2.36 (60)	3.94 (100)	5.91 (150)	7.87 (200)	9.84 (250)	<p>(marking in the outer radius)</p>  <p>the minimum radius is built with only 2 bolts</p>
radius	3.94 (100)	5.91 (150)	7.87 (200)	9.84 (250)	11.81 (300)	<p>(marking in the outer radius)</p> 
radius	5.91 (150)	7.87 (200)	9.84 (250)	11.81 (300)	15.75 (400)	<p>(marking in the outer radius)</p> 
radius	9.84 (250)	9.84 (250)	11.81 (300)	15.75 (400)	19.69 (500)	<p>(marking in the outer radius)</p> 
radius	-	11.81 (300)	15.75 (400)	19.69 (500)	23.62 (600)	<p>(marking in the outer radius)</p> 



# SLE ASSEMBLY

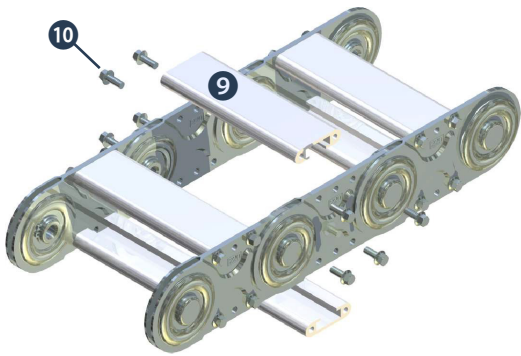

## STAY REMOVAL

The stays (9) are fastened with serrated screws (10) to the links (1). They can be removed by unscrewing the four screws (10). Stay lengths up to 600 mm are available with quick assembly.

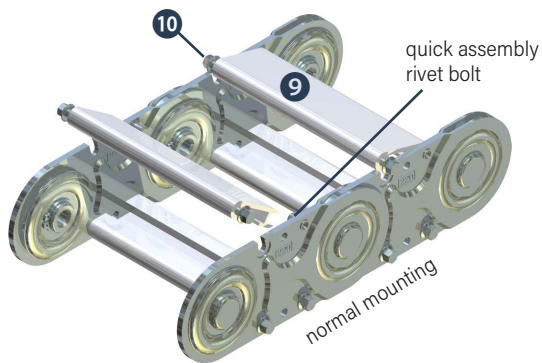

## QUICK ASSEMBLY

In quick assembly only two screws must be tightened or loosened. The stays (9) are moved with the groove on the rivet and the serrated screw (10) snapped in the recess and tightened.

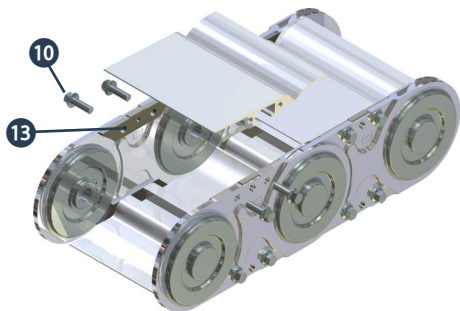

## SILVER STAR COVER

The covers of the closed version can be removed like the stays by loosening the four serrated screws (10). The spacers (13) remain on the links.

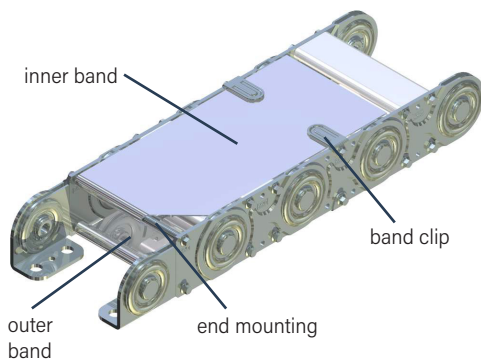

## STAINLESS STEEL BANDS

To protect the lines against external damage and pollution the carriers can be equipped with steel or stainless steel bands in the inner and outer radius. The edges of the steel bands are circular smoothed to avoid injury. Stainless steel and steel bands are fastened with band holders screwed on sides and with screwed connections on each end of the chain.



# SLE ASSEMBLY

## FINAL ASSEMBLY

The installation height should not fall below the level  $H = (50 \text{ plus two times bend radius plus link height})$ . The pretension of cable carrier is taken into account with the additional space of 50 mm. First fasten fixed connection (F) and then mount the movable connection using the specified bolt size.

Compliance with the maximum free carrying length is of vital importance for the life time of the cable carrier, both during the installation as well as when operational. Over travel of the cable carrier can lead to damage and premature wear.

If the cable carrier is provided with support elements, the assembly of these must take place before the installation of the chain in order to avoid even a short-term stress point.

An cable carrier may never exceed the free carrying length without support rollers.

The height of the moved connector must be adjusted so that the connector link is moving with a maximum of 5 mm distance from the base of the supporting roller.

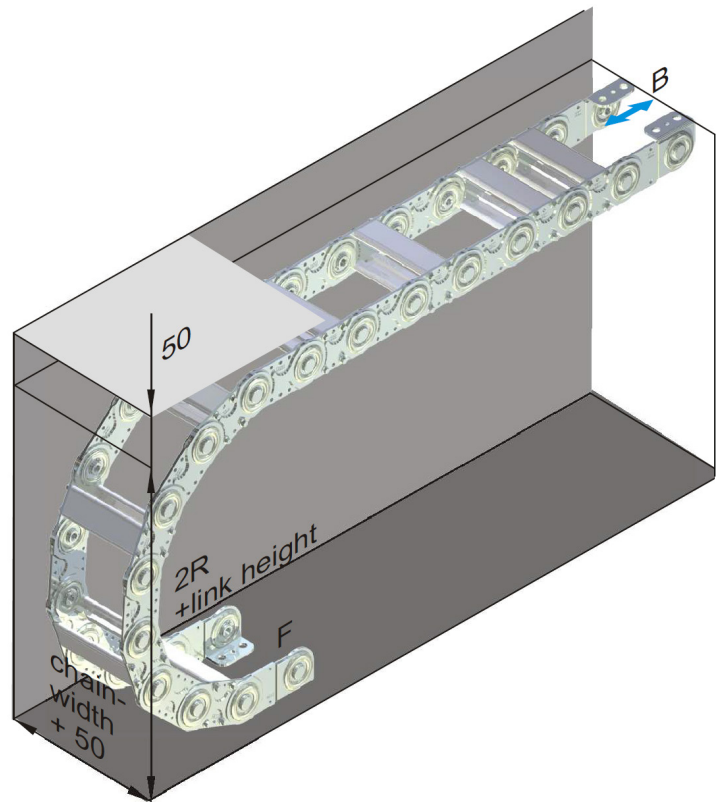

## MAINTENANCE OF THE CARRIER

Like every mechanical system this will depend on the ambient conditions so wear will occur which must be observed.

For long travels or in a circular motion, the cable carriers are often equipped with sliding elements. These allow sliding of the upper part of the chain on a suitable surface (eg, slider, slider-steel, glide bar).

The sliders wear depends on the application.

The slider surfaces should be checked at regular intervals. With a thickness of 1-2 mm sliders have to be replaced.

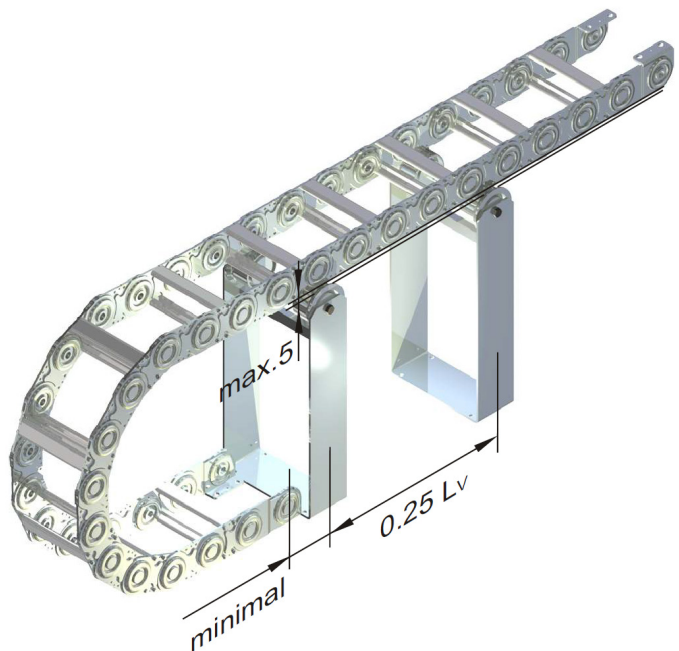

# SLE ASSEMBLY

## SUPPORT BRACKETS & ROLLERS

- Support rollers are used when half of the travel exceed the free carrying length.
- Support rollers allow four times extension of travel distance
- Roller Ø100mm for all sizes
- The steel support rollers are delivered with robust high quality support frames. The height of the moved connector must be adjusted with a maximum 5mm distance from the base of the supporting roll.
- As an alternative to steel rollers (SR), plastic support rollers (PR) for plastic chains are available.

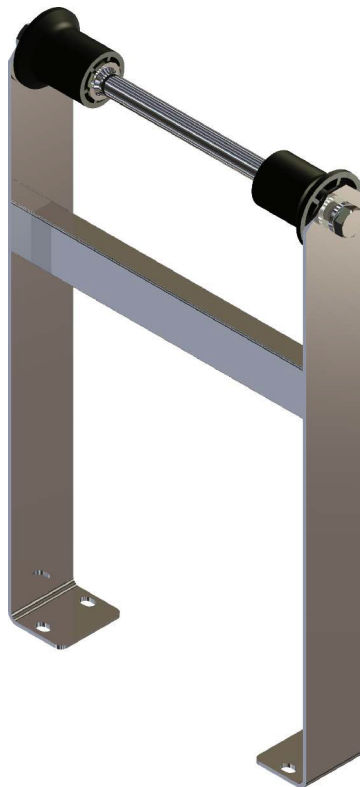
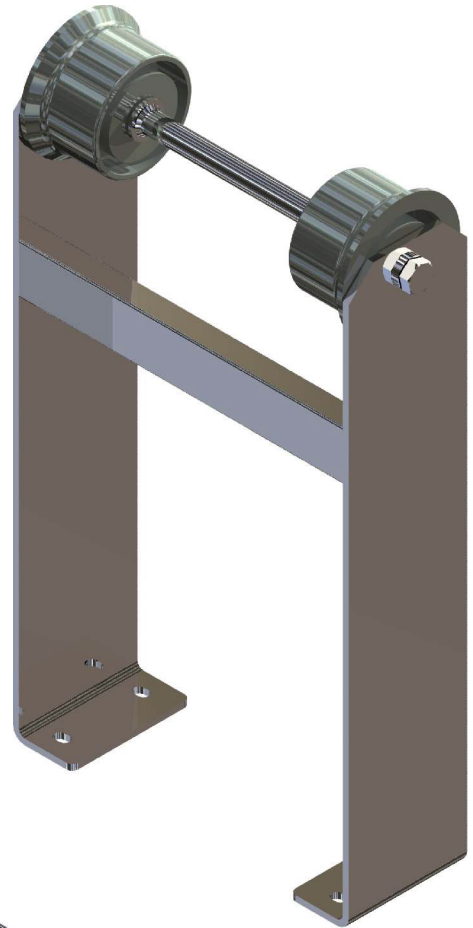

# SLE ACCESSORIES

## FLANGE ROLLERS

The flange rollers are used for very long chains in combination with a support railing with supporting rollers and support frames

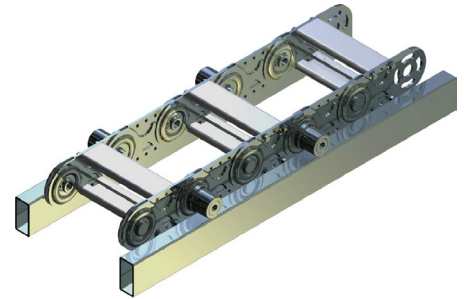

## GUIDE ROLLERS FOR STEEL CARRIERS

Guide rollers are used for steel chains in arrangement u (moving end downside). In this case provide a trough or a corresponding support rail.

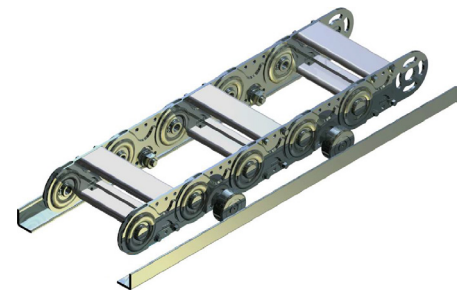

## GLIDING DISC FOR STEEL CARRIERS

For the SLE in arrangement w (lying horizontally on the side) for the longest travel distance or in arrangement k (circular) gliding discs are used. The gliding discs are made of high quality, highly abrasion-resistant materials. In both arrangements a guide is necessary.

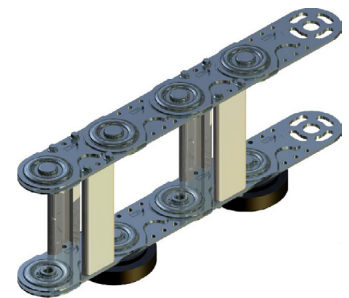

## SHELF TROUGHES FOR STEEL CARRIERS

Shelf troughs consist of two standard angular channels that are welded together from 3m lengths. Shelf troughs will be used if a smooth and precise guidance of steel chains is necessary.

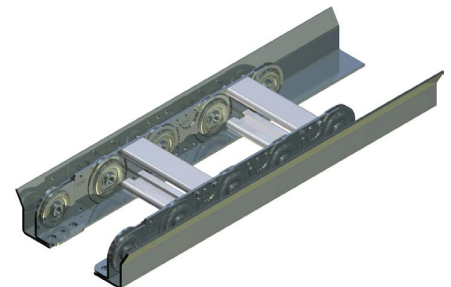

## SUPPORT CARRIAGE FOR STEEL CHAINS

Steel chains with support carriage are used for long travel distances and very high additional weights in a counterchain arrangement. With side-mounted guide rollers the cable carriers are supported on the support carriage.

Technical Features: No push—just pull—tension, large travel distances, extreme additional loads, smooth running, long life.

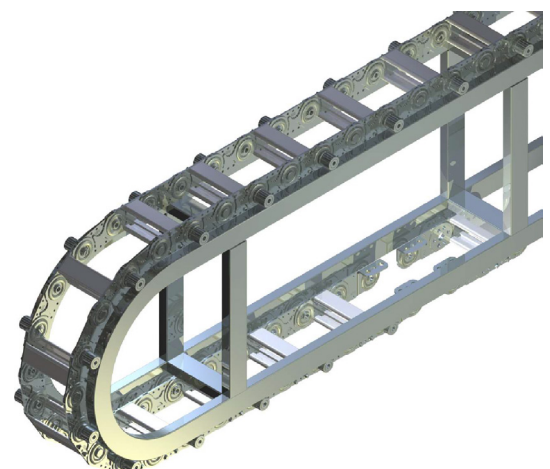

# CONSTRUCTION & AGRICULTURAL VEHICLES

Hennig cable carriers have rugged designs that can handle the unsupported spans, shock loading capabilities, and extreme environments and duty cycles typically found in construction and agricultural vehicles and applications. Hennig cable carriers are available in plastic, steel, and hybrid construction.

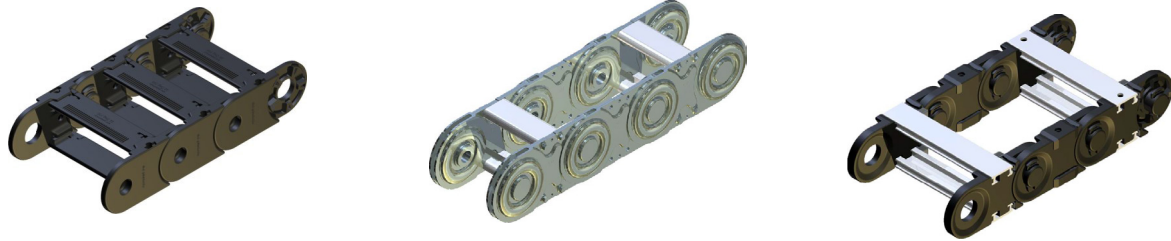

Hennig has the engineering & fabrication capabilities to deliver turn-key systems.



## ADVANTAGES

- Easy to assemble & maintain
- Pre-installed cables & hoses available
- Tow arms & mounting fixtures available
- Quick connect frame stay designs available

## APPLICATIONS

- Horizontal directional drillers
- Seat extenders
- Screeds
- Stacker/reclaimers
- Agricultural automation
- Oil & gas (offshore & onshore)

## MARKETS

- Construction
- On and offshore drilling
- Top rigs
- Cranes
- Robotic transfer units
- Large workpiece loading

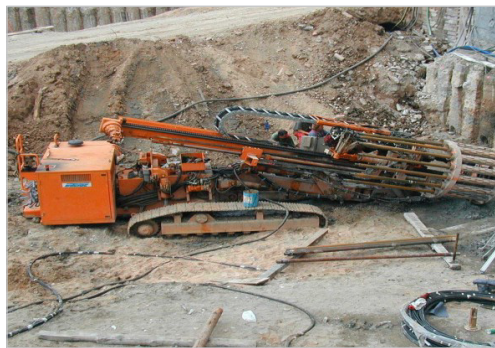



# ELEVATING WORK PLATFORMS

- **Lightweight**
- **Cost Effective**
- **Longest Available Unsupported Spans**
- **ROHS/REACH Compliant**
- **Safe & Easy to Handle**
- **Easily Field Serviceable**
- **Forward Placement Programs Available**

MEWP Cable & Hose Carrier applications are among the most demanding anywhere. They require products that are robust enough to handle the longer unsupported spans of telescopic booms, but light enough for minimum counterweight requirements. They also need to be priced competitively and meet industry safety and environmental requirements. Hennig offers two carrier series specifically designed to support the MEWP Industry.

## SPANTRACK

- Steel cable carriers are typically used on telescopic boom applications with travels over 45 ft, due to unsupported span requirements.
- Hennig Spantrack is constructed from a specially engineered polymer blend, resulting in a plastic carrier with up to twice the unsupported span capabilities of standard plastic carriers.
- Spantrack systems can typically replace steel carriers on stick boom applications with travels up to 60 ft, offering significant cost and weight savings.

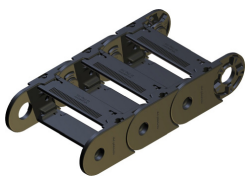

## SMART TRACK

- Hennig SMART Track is a lightweight RoHS compliant, plated steel carrier solution designed for super and ultra-boom type applications with boom travels exceeding 60 ft.
- Hennig SMART Track offers longer unsupported spans than any other steel carrier system in its class.
- Hennig SMART Track weighs as much as 1.34 lbs/ft less than its closest sized competitor.

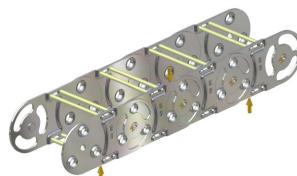



# ELEVATING WORK PLATFORMS

## CARRIER WEIGHT COMPARISON

Manufacturer	lbs/ft (kg/m)
Hennig SMART Track	3.5 (5.3)
Competitor A	5.1 (7.6)
Competitor B	4.6 (6.85)

## UNSUPPORTED SPAN COMPARISON

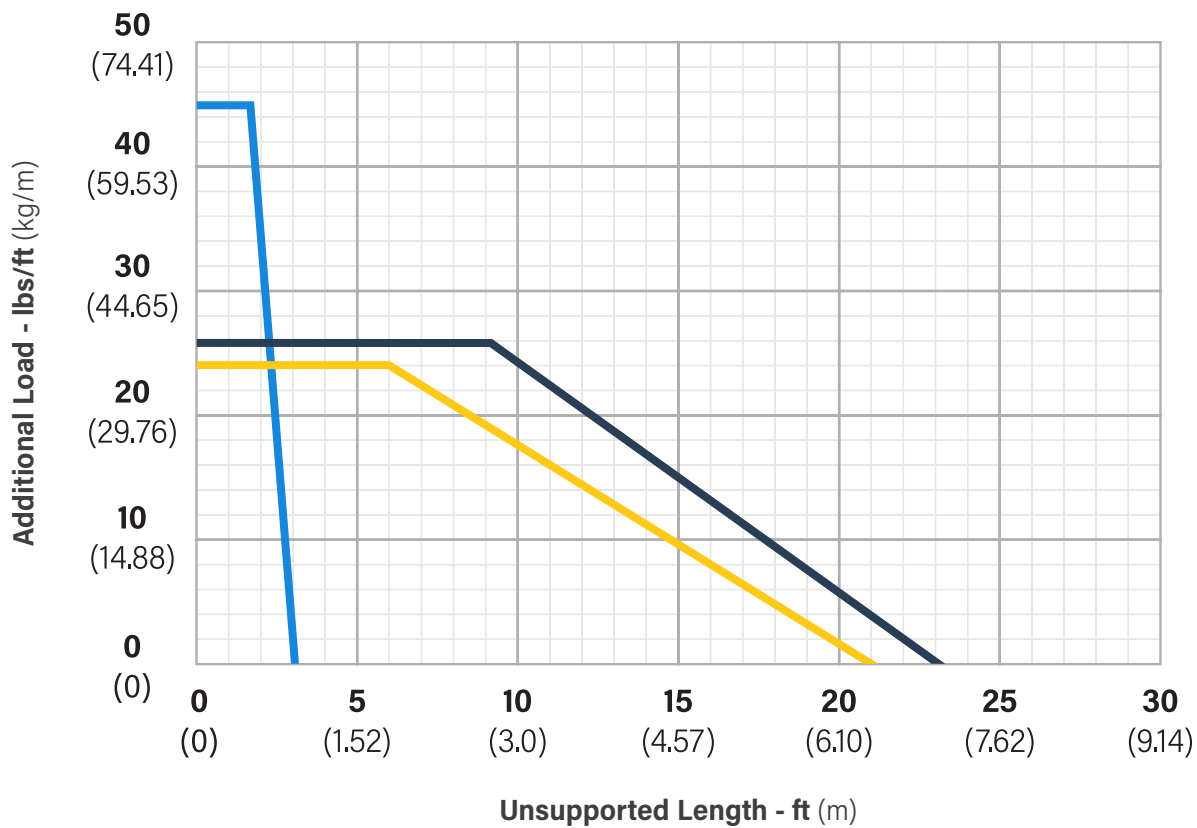

# DESIGN GUIDELINES

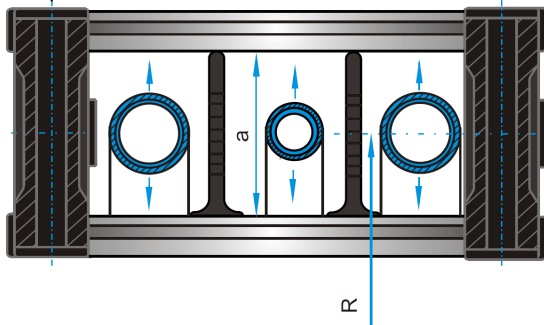
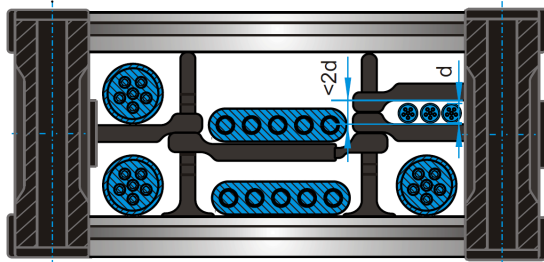
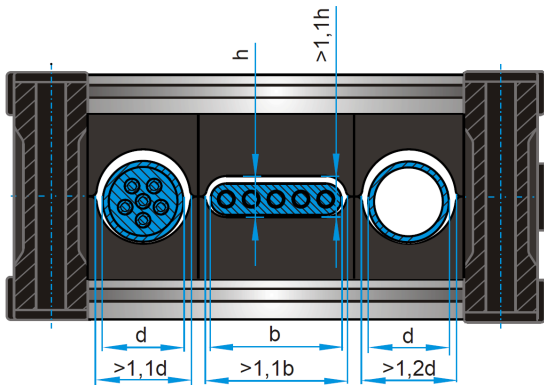

## SELECTION OF THE CABLE CARRIER MATERIAL

Plastic cable carriers are often the preferred choice for most applications. They offer significant advantages such as chemical resistance, lightweight materials, and cost-effectiveness. In cases of heavy payloads or specific requirements, steel chains are used to withstand extreme conditions. For exceptionally demanding cycles, our hardened (carburized) steel chains ensure exceptional longevity.

## CALCULATION OF CROSS-SECTION

First, the cross-section required for the wires is determined, and then specific motions or arrangements, aggressive environmental conditions or other factors lead to your selection. A pre-selection of the product series may use the fields of application. All lines must be able to move freely in the cable carrier. This requires an individual clearance to be taken into account for each line:

- round cable:** 10% of the diameter
- flat cable:** 10% of the cable width and height
- hoses:** 20% of hose diameter

Optimum requirement is the separation of all lines by means of individual chambers. Especially with varying diameters or multi-layer wiring a separation by vertical and horizontal dividers is required. If several lines are to be laid in one chamber, the chamber dimensions have to be restricted so that they maintain their relative positions. Even multi-layer arrangements of flat cables have to be separated with horizontal dividers.

When using pressure hose a change in length has to be taken into account through additional clearance in the chain bow (radius), which can be achieved by a corresponding chain height (a). The distribution of the cable carrier cross-section should be symmetrical in order to ensure an uniform load. In addition heavy lines are laid out close to the links to minimize the bending loads on the transverse bars.

## DETERMINATION OF THE BENDING RADIUS

The bending radius of the cable carrier is determined by the minimum permissible bending radius of the cables and hoses, the available installation space and the polygon oscillation PA of the cable carrier. In general, a minimum bend radius of 10d is considered, where d is the largest existing line diameter. Cables with smaller minimum bend radii are available by some manufacturers.

The polygon oscillation PA influences the moving of an cable carrier. A large bend radius at the same pitch results usually in a calmer movement of the cable carrier. The installation space must have a height of more than 2R + c, where R is the set-radius and c is the link height of the cable carrier. The real radius is the set radius +0/-5%. The pretension of the cable carrier should also be considered.

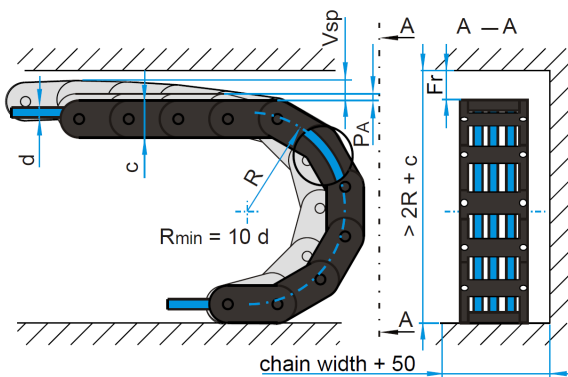

$$R = R_{set} +0/-5\%$$

$$Fr > 50 \text{ if } c < 70$$

$$Fr > 100 \text{ if } c > 70$$

# DESIGN GUIDELINES

## CABLE CARRIER LENGTH

In standard applications the fixed connector of the cable carrier is arranged in the middle of the travel distance. The moving connector moves horizontally over the fixed connector between the end positions of the travel. The required length of the cable carrier between the first and the last pivoting link is then determined as follows:

$$L = LV/2 + 4 R$$

- L length of the cable carrier
- LV length of travel
- R bending radius of the cable carrier

If the fixed connector is not in the middle of the travel, the cable carrier has to be extended by a displacement of x:

$$L = LV/2 + 4 R + x$$

- x offset of the fixed connector

After the selection of the cable carrier, the length is rounded up to the link pitch. This length is the ordering length of the cable carrier. The connectors height is double bend radius plus link height:

$$H = 2 R + c$$

- H connector height
- c link height of the cable carrier

$$(Total\ Travel/2 + Distance\ offset\ from\ center) + (\pi \times Radius) + 2\ links$$

## REVIEW OF THE FREE CARRYING LENGTH

The additional load is the weight of all cables and hoses, divided by the length of the chain:

$$ms = mL/L$$

- mL cable weight
- mS specific additional load

Thus with calculated additional load and the help of the load diagram the free carrying length of the cable carrier can be verified.

If the additional load is too high for a particular chain an cable carrier with greater free carrying length is chosen or constructive changings have to be done that allow the operation with the chosen cable carrier (eg, gliding arrangement, support rollers, SYSTEM MARATHON or similar).

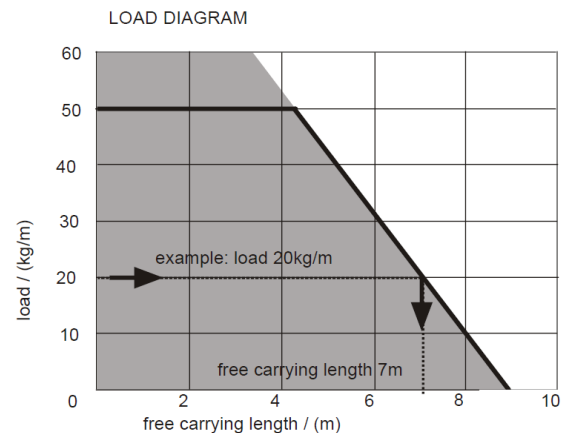
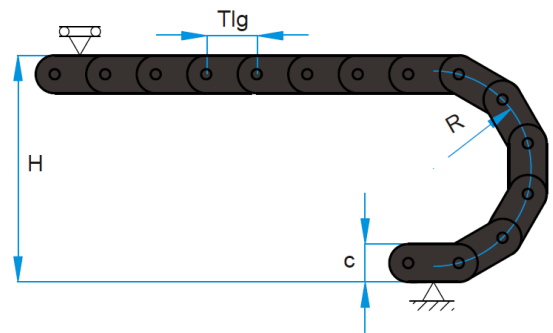
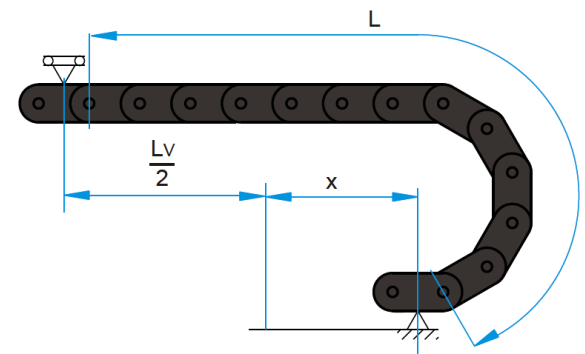
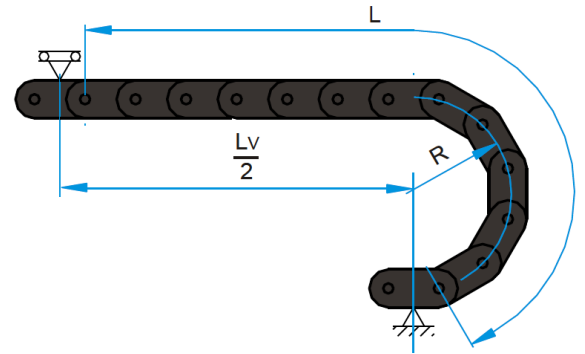

# DESIGN GUIDELINES

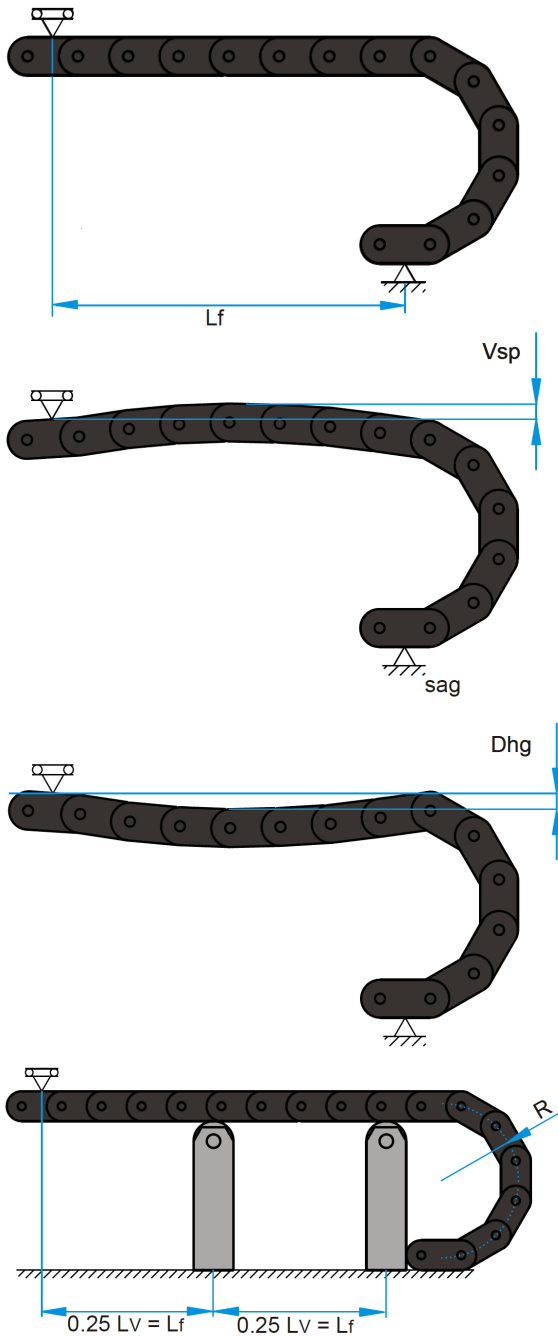

## PRETENSION AND PERMISSIBLE SAG

Cable carriers are supplied with pretension. Exceptions are for vertical or sliding arrangements as well as on the side lying cable carriers, for example, in a circular arrangement.

The pretension is a manufacturing tool to achieve cable carriers with increased free carrying lengths. The values for the pretension is set by the manufacturer. Our cable carriers made of steel are manufactured with 5 mm / m and plastic cable carriers up to 25 mm/m as pretension with no load.

The sag is due to the additional load and the weight of the cable carrier. Due to the significantly lower elongation of steel (0.2% linear elongation) compared to plastics the permissible sag of the steel chains is limited lower than for plastic cable carriers.

On the other hand, the effect on plastic cable carriers of a long-term static load with a long unsupported length of the upper strand chains will increase the sag (creeping of plastics). Elevated temperatures and humidity increases this effect. The sag of cable carriers is also increased by use-wear.

The maximum allowable sag can only be judged in the assessment of all operating conditions. Within the limits for the free carrying length specified in the load diagram the sag is within the permissible range at normal operating and environmental conditions.

In addition the following factors have to be taken into account: Using toughs and slow moving cable carrier sag is limited.

For high accelerations and high travel speeds too much sag is a problem. A defined force application at the moved connector is not guaranteed and uncontrollable chain oscillations can occur. Thus the cable carrier material is subjected to extreme dynamic stresses. In such cases, corrective steps should be taken.

The first step is the selection of an cable carrier with increased free carrying length. If this can not be done, see page 6 for alternatives.

# DESIGN GUIDELINES

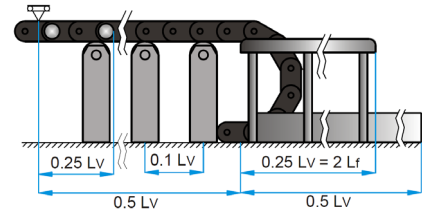

## SUPPORT ROLLS AND SUPPORT RAILS

Support rollers can increase the maximum travel LV of steel chains by up to four times the free carrying length Lf. With additional support rollers and a support rail the maximum range of movement can be expanded up to eight times the free carrying length. The use of support rollers with support frames, is limited to speeds below 1 m/s.

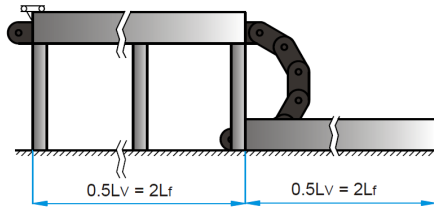

## RAISED TROUGH

This type is mainly used with plastic cable carrier applications. As with the use of support rolls the maximum travel can be increased up to four times the free carrying length. Because of the larger permissible sagging, support rolls are not suitable for plastic cable carriers.

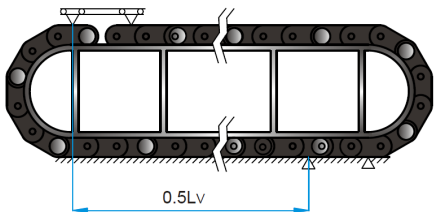

## SUPPORT CARRIAGE

For long travel distances and high additional loads support carriages can be used with reverse traveling cable carriers. The side-mounted support rolls carry the cable carrier and move the support carriage. The cable carriers now only face pull forces and through this an extremely long life is achieved even at high additional loads.

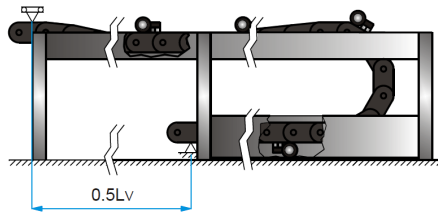

## SYSTEM MARATHON

The patented SYSTEM MARATHON for unlimited travel is also designed for high speeds and high accelerations. The upper run is running with supporting rollers over the entire travel on continuous flat rails and the rollers swing in the radius to lay down the cable carrier at the bottom profile. In the back movement the rollers swing out again and lead the cable carrier without wear over the entire travel. The SYSTEM MARATHON is not dependent upon the type of cable carrier and therefore steel cable carriers are as equally suitable as plastic cable carriers.

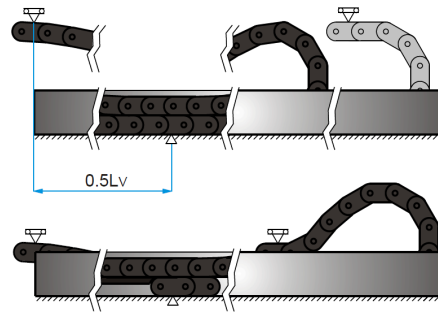

## GLIDING CABLE CARRIERS

Gliding cable carriers require guiding the upper run in a continuous trough. In addition, the first half of travel slide bars are mounted or the cable carrier is extended via the fixed end in the middle of the travel out up to the starting point to create a continuous gliding plane (see also chapter troughs).

With high dynamic demands on the cable carrier, lowering the moving connection end may be necessary to result in a better introduction of push forces into the cable carrier. In travels over 30 m, velocities above 1.5 m / s and acceleration of 1 m/s<sup>2</sup> lowering the moving end is recommended and requires an additional length of the cable carrier. Chain links with a opposite bend radius minimize the required additional length and minimize oscillations of the remaining free carrying length of the cable carrier.

PKK, PLE and SLE cable carriers for gliding arrangements are preferably equipped with sliders that can be replaced after reaching the wear limit without dismantling or replacing the cable carrier.



# ARRANGEMENTS

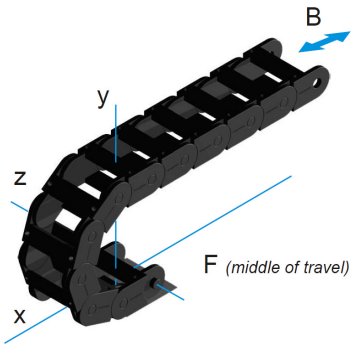

## NORMAL ARRANGEMENT (N)

In the normal arrangement the fixed connector is usually on the first link in the lower strand in the middle of the travel. The moving end connector is moving the chain in a straight line lengthwise at a height of  $2R+c$  over the entire travel. The upper strand is steadily reduced through the bending of the individual links until the whole chain length is taken to the bottom or in a trough.

This arrangement allows maximum speeds and extreme acceleration with optimum durability.

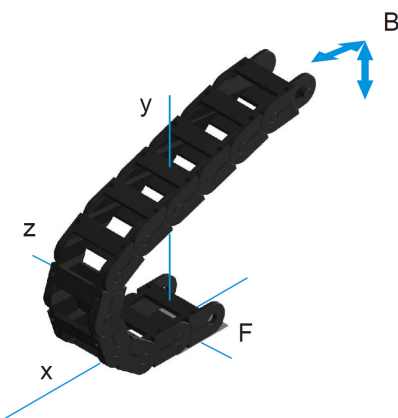

## MULTIAXIAL (M)

In the multiaxial arrangement is a vertical and horizontal motion of the driver along the x-axis (travel direction) and one or more movement in the y- or z-direction. While running in the y-direction may be done by any conventional cable carrier, the movements in the z-direction require the cable carrier system ALLROUND.

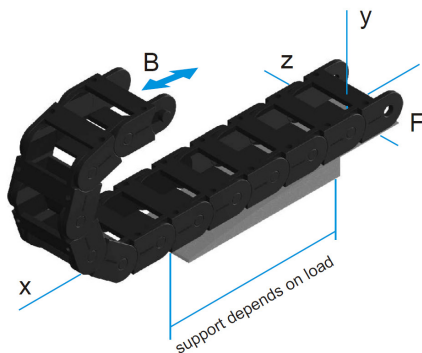

## FREE OVERHANG (F)

In contrast to the normal arrangement the freely exceeding lower strand is supported only partially by a substructure. Due to the high weight load on the lower strand in this arrangement only significantly reduced travel distance is possible.

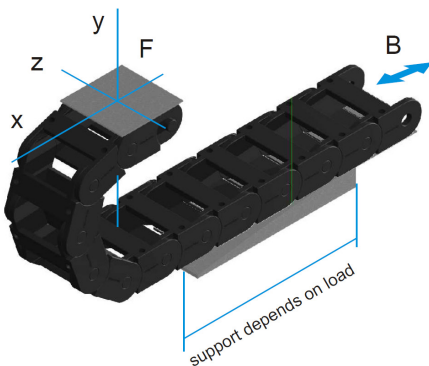

## MOVED END DOWNSIDE (U)

If the driver is positioned in the lower, due to the heavy weight only a reduced travel distance is possible (see above).

# ARRANGEMENTS

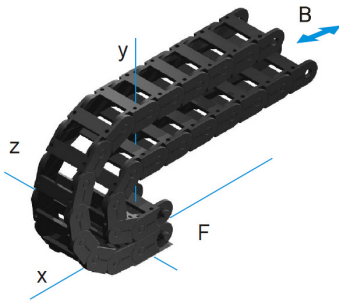

## NESTED TRAVEL (I)

The arrangement of two or more cable carriers with different bending radii or even different cable carriers makes sense when using a variety of cables and hoses together. The cable carriers are moved together by a common driver.

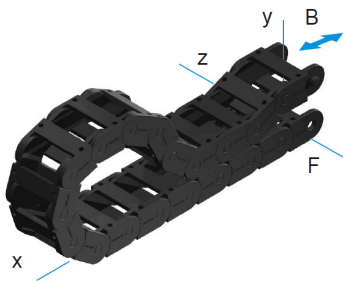

## GLIDING ARRANGEMENT (L)

If the free carrying length is exceeded, the cable carrier changes into a gliding state. In this arrangement, use cable carriers without pretension. A trough is required. Sliders increase the lifespan and can be replaced if necessary.

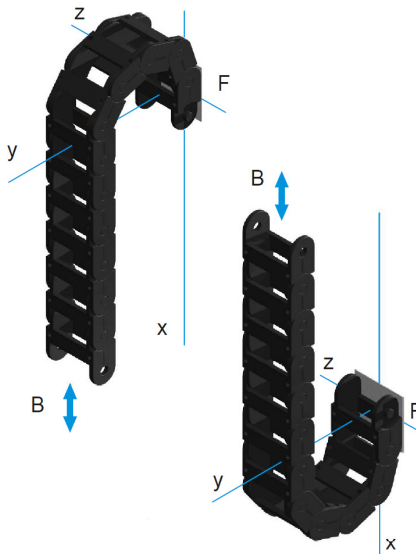

## VERTICAL TRAVEL (S)

Vertical travel arrangements are often installed in systems in which multiple linear axes are coupled. In this arrangement usually cable carriers without pretension are used. Vertical arrangement with multiaxial movement needs chains with pretension. The weight of the lines and of the cable carrier has to be placed and pushed by the straight part of the chain. This forces should be caught by a support. The cable carrier should be arranged so that optional cross accelerations are in the y-direction.

## VERTICALLY HANGING (H)

Elevators, high-bay stores and doors are typical applications for cable carriers in vertically hanging arrangement. In this arrangement the cable carrier is predominantly tensile stressed. Lateral acceleration should be layed if any, in the y-direction. Cable carriers are without pretension.

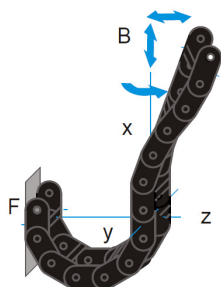

## HANGING MULTIAXIAL (HM)

The ALLROUND cable carrier provides the combination of linear and rotary motion.

# ARRANGEMENTS

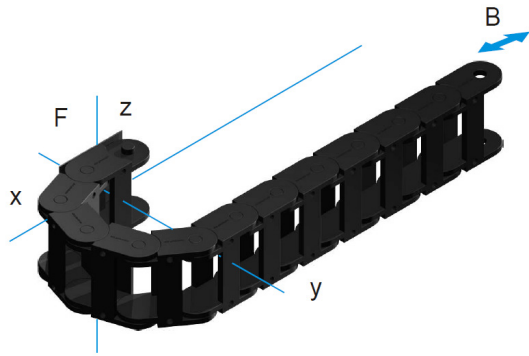

## HORIZONTAL (W)

(on the side)

Cable carriers are arranged horizontally lying on their side, for example, if the space does not allow a normal arrangement. In some cases, lying on its side provides an alternative for very long traverse at low speeds and strokes. In this application mainly chains without pretension are used. In general, suitable guide troughs and gliding discs or rollers are required.

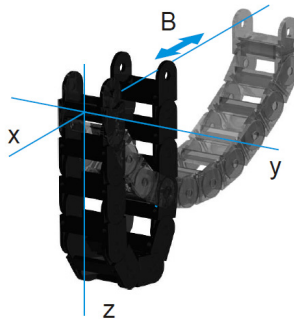

## DRIVING APART (A)

With cable carriers moving apart the calculation of the cable carrier length does not follow the usual pattern, but be adapted to the individual requirements of the application.

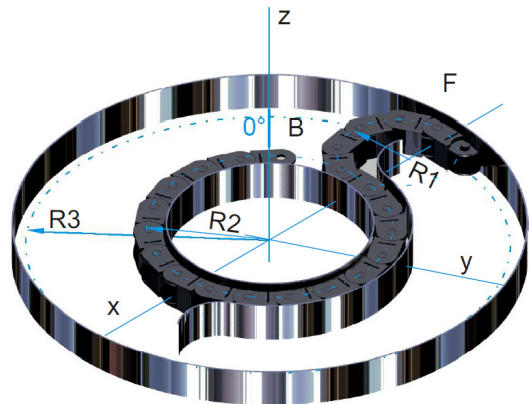

## CIRCLE (K)

(on the side)

The circular motion is a special form of chain movement. For circle movement a part of the cable carrier has to be manufactured with an opposite bending radius R2. The outer radius R3 is derived from the link height, the bending radius of the cable carrier R1 and the opposite radius R2.

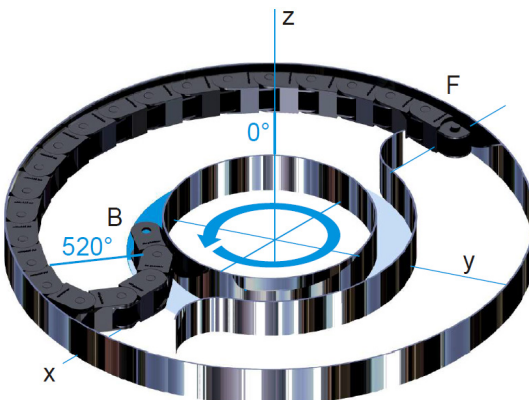

This type of horizontal arrangement allows rotation up to 520°. A customized guide channel is required.

# WIRING

Cable carriers are arranged horizontally lying on their side, for example, for placing in only highly flexible cables with permissible bending radii and sufficient dynamic capacity suitable. The cables have to be laid twist free to move freely lengthwise. Cable on a reel should be unrolled in the reverse winding direction and placed in the extended state in the cable carrier. For intermediate storage the lines are ideally laid out straight. The material relaxation occurs in this case facilitates a twist-free installation.

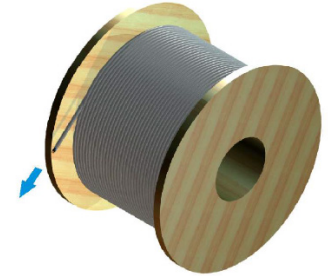

The distribution of the chain interior must prevent mutual interference between the wires with dividers or wrap clamping of different diameters safely, so that each line can move freely in the longitudinal direction. In particular in the cable carrier radius tensile stressed wires increase wear drastically and reduce the reliability. A fixation of the wires or a bundle of several lines using cable ties or the like within the cable carrier can also cause damage.

## STRAIN RELIEF

With long travel distances and high speeds the cables should be attached with strain relief only at the driver end. For free carrying cable carriers, a strain relief on both ends is recommended for aesthetic reasons. The distance of strain relief to the bending stressed area depends on the particulars of the line manufacturer. Hydraulic hoses have special needs.

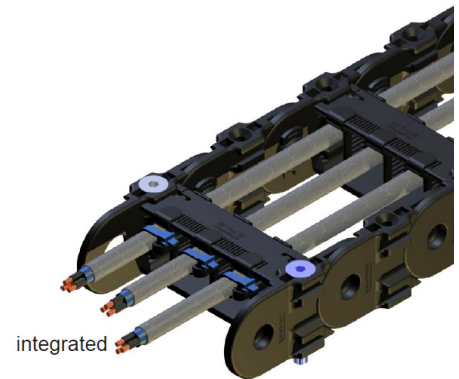

### INTEGRATED STRAIN RELIEF

In this space-saving type the strain relief is directly attached to the plastic dividers (PZ) in the first link of the cable carrier (note the mounting direction of PZ). In order to avoid premature line wear caused by dynamic loads, a small excess length of the chain is recommended .

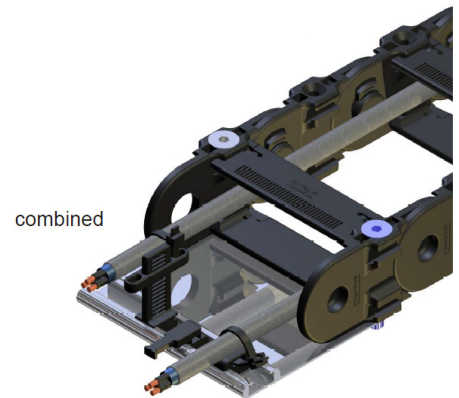

### COMBINED STRAIN RELIEF

The combined strain relief combines the advantage of a sufficient distance from the bending line areas to the strain relief by the simple and space-saving installation of the integrated strain relief. The anchor profile is provided to the drilling dimensions of the cable carrier and attached to the chain. The lateral insertion and extraction of strain relief elements is through the C-profile.

### SEPARATE STRAIN RELIEF

The separate strain relief is recommended for high dynamic loads and large line diameters. A sufficient distance of the strain relief to the moved line areas and length compensations are easy to implement. In this variant the lateral insertion and extraction of the strain relief elements with no installation work on the cable carrier is possible.

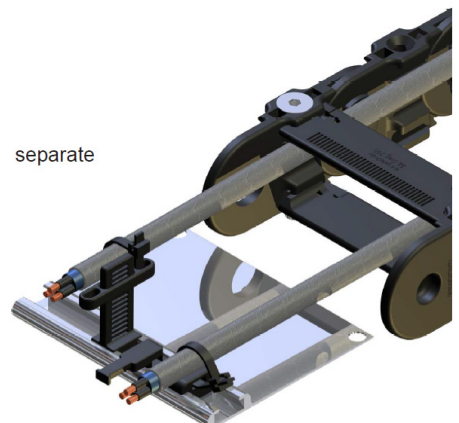

# QUOTE REQUEST

Please complete this form and email to info@hennig-inc.com.

## COMPANY (name & complete address)

\_\_\_\_\_  
 \_\_\_\_\_  
 \_\_\_\_\_  
 \_\_\_\_\_

Name \_\_\_\_\_  
 Title \_\_\_\_\_  
 E-mail \_\_\_\_\_  
 Phone \_\_\_\_\_ Fax \_\_\_\_\_

## CARRIER DESIGN INFO

Type of Cable/Hose \_\_\_\_\_ Quantity \_\_\_\_\_ Unit of Measurement  inches  millimeters  
 Outside Diameter \_\_\_\_\_ Minimum Bend Radius \_\_\_\_\_ Weight/Foot \_\_\_\_\_ Dividers Required  yes  no

**A = Cavity Width** \_\_\_\_\_  
 Add the outer diameter of all cables/hoses plus the appropriate safety factor.  
 (Cables + 10%, Hoses + 20%)

**B = Cavity Height** \_\_\_\_\_  
 Add the outer diameter of all cables/hoses plus the appropriate safety factor.  
 (Cables + 10%, Hoses + 20%)

**C = Outer Width** \_\_\_\_\_  
 Please identify any space restrictions

**D = Outer Height** \_\_\_\_\_  
 Please identify any space restrictions

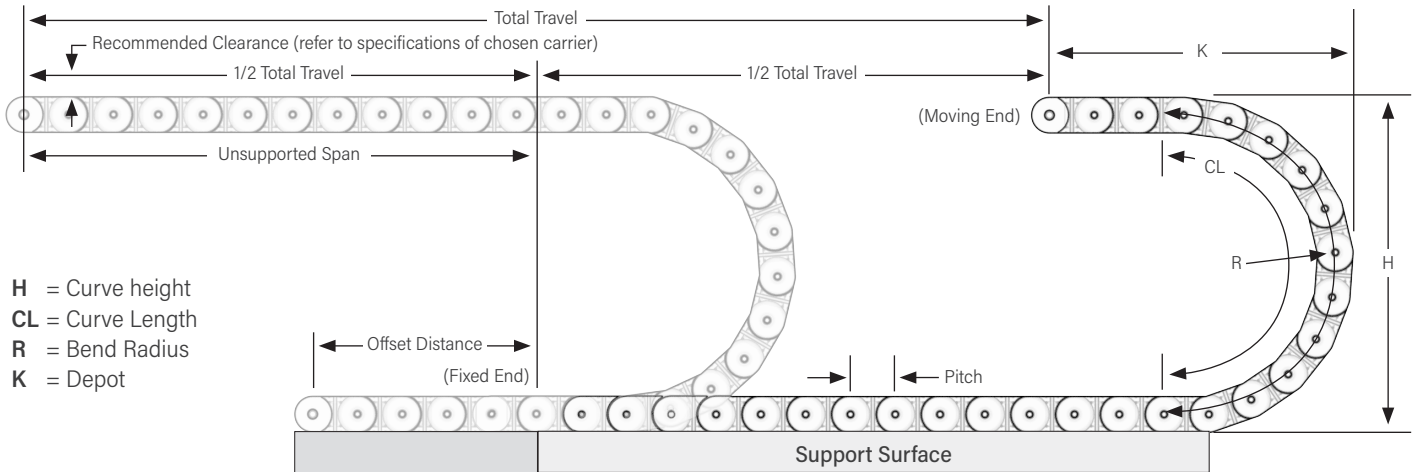
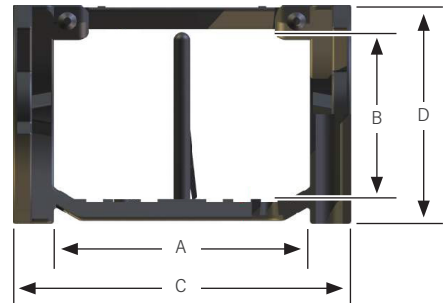

Total Travel Length \_\_\_\_\_ Will Fixed End be the Center of Travel?  yes  no (offset distance from center) \_\_\_\_\_  
 Maximum Travel Speed \_\_\_\_\_ Acceleration \_\_\_\_\_ Duty Cycle \_\_\_\_\_  
 List Space Restrictions (mounting height "H", depot "K") \_\_\_\_\_

## APPLICATION INFO

Material Preference  steel  plastic  no preference  other \_\_\_\_\_  
 Style Preference  enclosed  open  
 Operating Temperature Range  fahrenheit  celcius Ambient \_\_\_\_\_ Minimum \_\_\_\_\_ Maximum \_\_\_\_\_  
 Describe Operating Environment (debris, moisture, chemicals, etc) \_\_\_\_\_

Application Details/Additional Notes \_\_\_\_\_  
 \_\_\_\_\_  
 \_\_\_\_\_



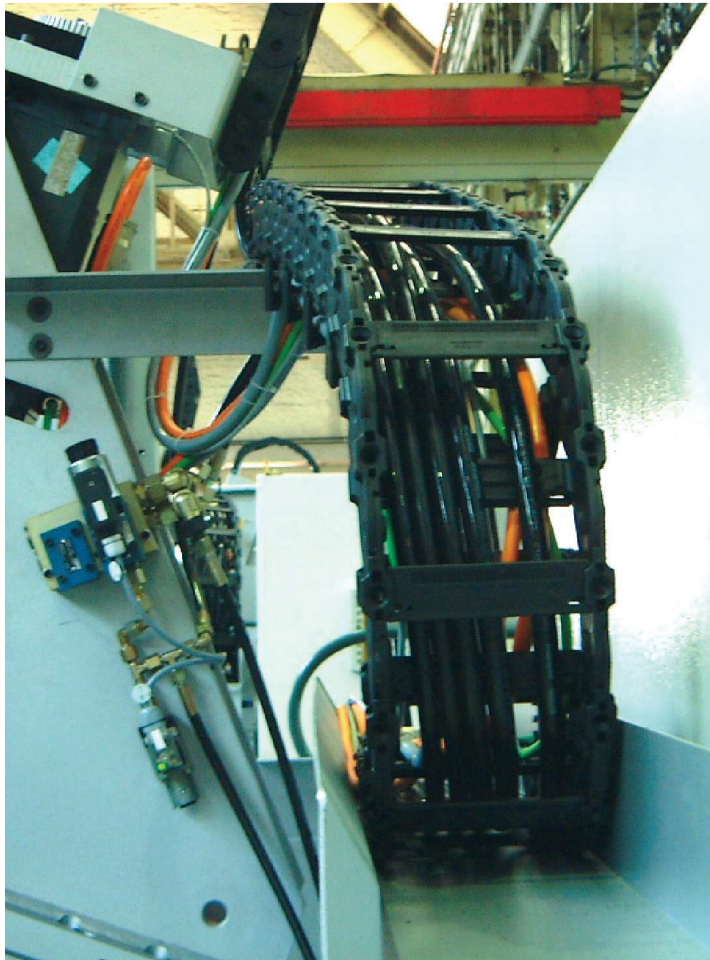

# FACILITIES & CONTACTS



- Headquarters / Manufacturing / Distribution / Service Center
- Manufacturing / Distribution / Service Center
- Manufacturing / Distribution
- Sales Partner
- Service Center



**1 Hennig, Inc. Global Headquarters**

9900 North Alpine Road  
Machesney Park, IL 61115  
P: + 01 815-636-9900  
F: + 01 815-636-1988  
info@hennig-inc.com

**4 Hennig, Inc. Ohio Service Center**

11431 Williamson Road  
Blue Ash, OH 45241  
P: + 01 513-247-0838  
F: + 01 513-247-0840  
info@hennig-inc.com

**7 Cobsen Ltda.**

R. Benedito Mazulquim, 425  
18550-000 Boituva CEP, Brazil  
P: + 55 15 3263-4042  
F: + 55 15 3263-4070  
cobsen@cobsen.com.br

**2 Hennig, Inc. Oklahoma Service Center**

900395 S. 3420 Road  
Chandler, OK 74834  
P: + 01 405-258-6702  
F: + 01 405-258-9971  
info@hennig-inc.com

**5 Hennig / Gaden, S.A. de C.V.**

Calle Primera N° 1037  
Col. Ministro Nazario Ortiz  
Saltillo, Coahuila, C.P. 25100  
P: + 01 (844) 180 0294  
F: + 01 (844) 180 029  
ventas@grupogaden.com

**3 Hennig, Inc. Michigan Service Center**

11879 Brookfield Road  
Livonia, MI 48150  
P: + 01 734-523-8274  
F: + 01 855-427-1549  
info@hennig-inc.com

**6 Hennig / Gaden, S.A. de C.V.**

Silca N° 4, Col. Vista Hermosa  
Tlalnepantla, Mexico, C.P. 54080  
P: + 52 (55) 5318 4146  
F: + 52 (55) 5319 32  
ventas@grupogaden.com



**8 Hennig GmbH European Headquarters**

Überrheinerstrasse 5  
85551 Kirchheim, Germany  
P: + 49 89 96096-0  
F: + 49 89 96096-120  
info@hennig-gmbh.de

**9 Hennig CZ s.r.o.**

Klánovická 334  
250 82 Úvaly, Czech Republic  
P: + 420 2810 91610  
F: + 420 2810 91625  
info@hennig-cz.com

**10 Hennig France sas**

19, rue de Rebrillon  
03300 Creuzier-le-Neuf, France  
P: + 33 470 58 4740  
F: + 33 470 58 0022  
contact@hennig-france.com

**11 Hennig U.K. Ltd.**

Unit 6, Challenge Close  
Coventry CV1 5JG, United Kingdom  
P: + 44 24 76555690  
F: + 44 24 76256591  
sales@henniguk.com

**12 Hennig BH doo.**

Ciljuge II bb – poslovna zona  
75270 Zivinice, Bosnia Herzegovina  
P: + 387 35 95 1876  
kontakt@hennig-bh.com

**13 B & S Industrieel Onderhoud**

Zirkoonstraat 7, 7554 TT Hengelo (Ov.)  
Postbus 69  
7550 AB Hengelo (Ov.), Netherlands  
P: + 31 74 8510600  
F: + 31 74 8510605  
hinders@bs.nl

**14 Svenska Maskinkomponenter AB**

Brunnsäkersvägen 9  
64593 Strängnäs, Sweden  
P: + 46 8 53470770  
F: + 46 8 53470775  
info@svemako.se

**15 Osung Mechatronics Co. Ltd.**

Jinbuk-myun Shincon-li 413-2  
Gyungnam Masan-city, South Korea  
P: + 82 55 271 1821  
F: + 82 55 271 1820  
osgijeon@naver.com

**16 Enomoto BeA Co., Ltd.**

5-10 Sohara Koa-Cho  
Kakamigahara-Shi,  
Gifu 504-8551, Japan  
P: + 81 583 832178  
F: + 81 583 897435  
kashida@enomotoweb.com





**||| HENNIG®**

**PROTECT** YOUR SUCCESS

# WE'VE GOT YOUR BACK

Hennig Worldwide has been a global leader since 1950, specializing in chip and coolant management, machine protection, and facility safety. We work with a wide variety of manufacturers and other facilities worldwide, helping them create and maintain safe and efficient workplaces. Our commitment to excellence extends beyond our services—we actively contribute to local communities, create regional jobs, and support the global needs of machine tool customers.

9900 North Alpine Road  
Machesney Park, IL 61115  
815.636.9900

[hennigworldwide.com](http://hennigworldwide.com)

CC0823